

Beschläge / Fittings / Ferrures
pour meubles / Ferrature / Herrajes

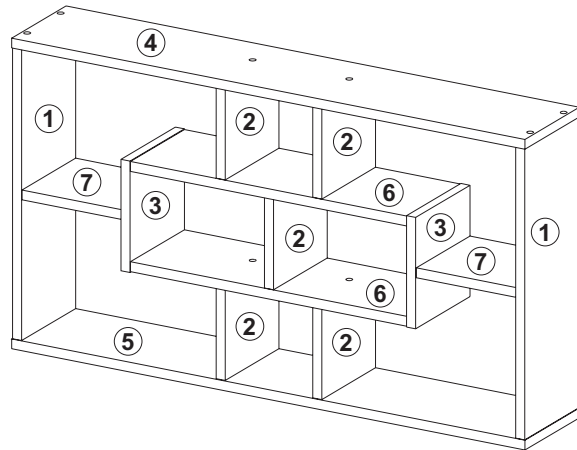
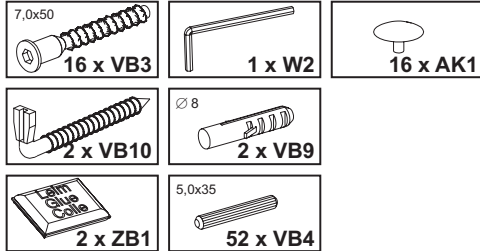

Sie benötigen:
You need:

Vous avez besoin de:
Bisogna avere:
Necesita:

2 Pers.

Cleaning information!

Clean only with a duster or damp cloth. Avoid using detergent or solvents!

Consigne d'entretien:

Nettoyer uniquement à l'aide d'un chiffon à poussière ou d'un torchon humide. N'utiliser aucun produit nettoyant!

Istruzione di pulizia:

Pulire unicamente con un panno per la polvere o con uno straccio umido. Non utilizzare prodotti detergenti abrasivi!

Indicaciones de mantenimiento:

Limpiar sólo con un trapo para el polvo o con un trapo húmedo. No utilizar productos de limpieza abrasivos.

Pflegehinweis!

Bitte nur mit einem Staubtuch oder einem feuchten Lappen reinigen. Keine scheuernden Putzmittel verwenden!

Teile / Article / Pieces / Elementi singolo / Piezas

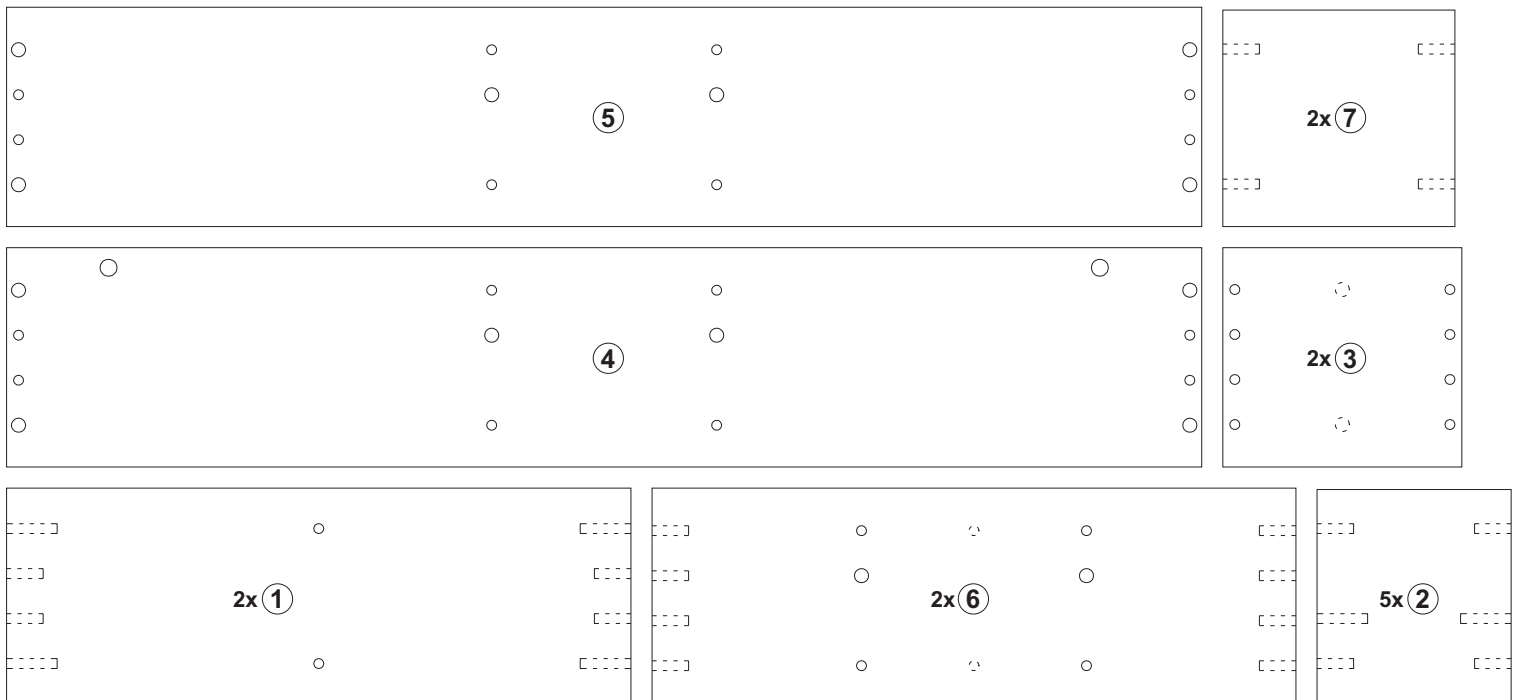

Bitte die Montageanleitung vor Beginn sorgfältig studieren. Um eine ordnungsgemäße und mangelfreie Erstellung zu gewährleisten, muß die Montage exakt in der gezeigten Reihenfolge ausgeführt werden.

Please study the instruction carefully before you begin. To achieve the best results please use these instructions the way they are printed starting at the beginning.

Lire scrupoleusement les instructions de montage avant de commencer le montage. Afin de garantir une construction conforme et irréprochable, le montage doit être effectué exactement dans l'ordre indiqué.

Per favore prima dell'inizio studiare accuratamente le istruzioni per il montaggio. Per garantire una realizzazione senza errori, il montaggio deve essere fatto rispettando esattamente la sequenza indicata.

Antes de empezar lea detenidamente las instrucciones de montaje. Para garantizar una construcción adecuada y sin defectos, el montaje deberá llevarse a cabo en el orden exacto que se indica.

A

5,0x35
52 x VB4

2 x ZB1

B

7,0x50
4 x VB3

1 x W2

2 x ZB1



C

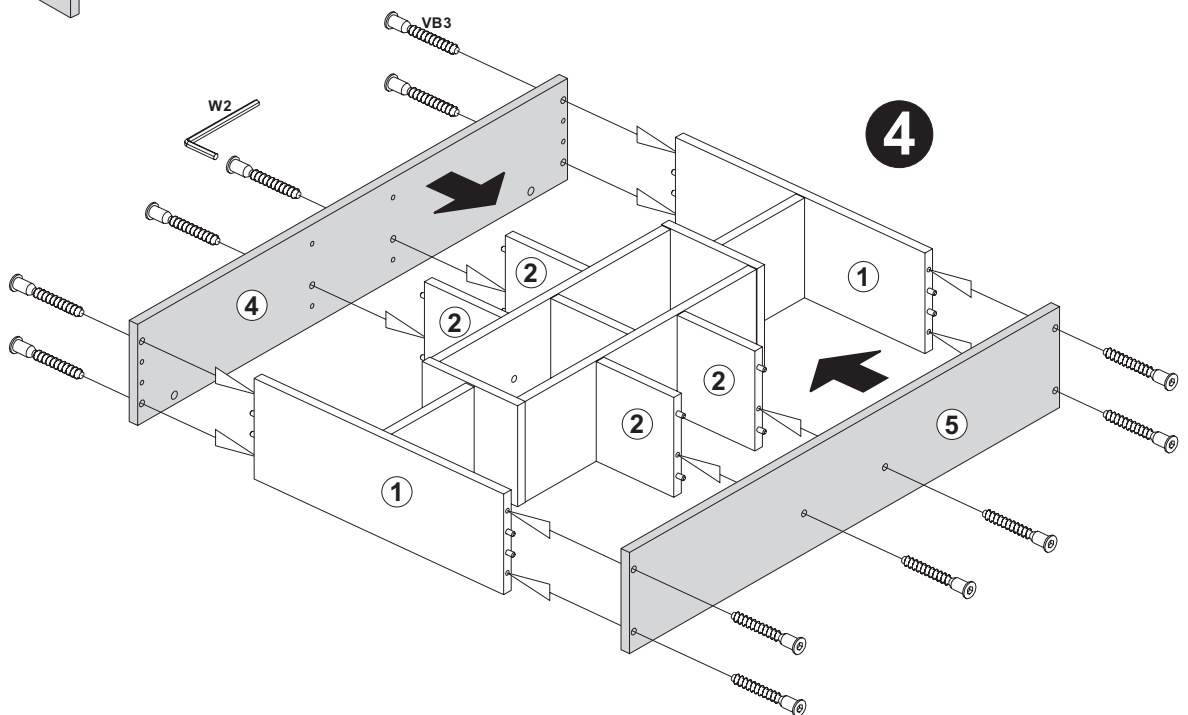
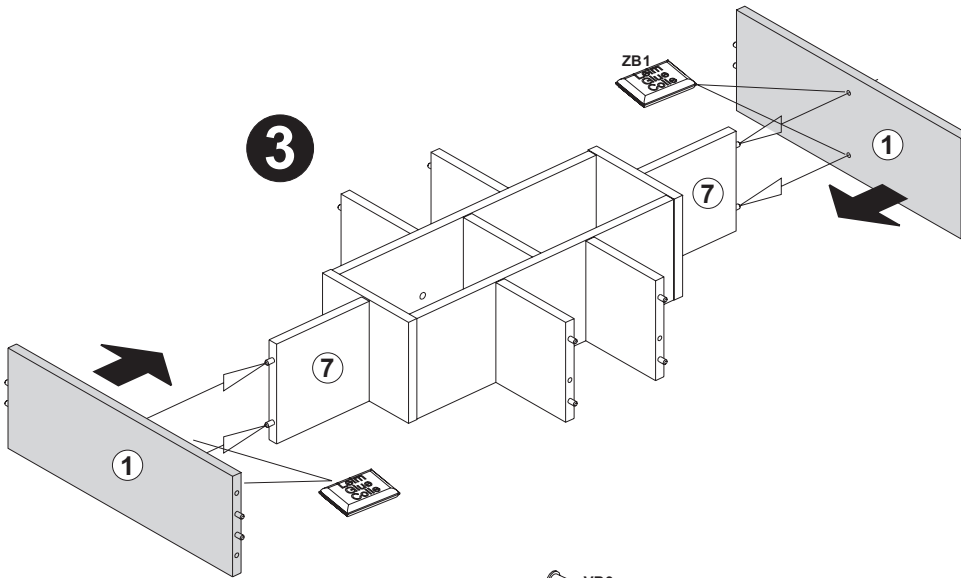
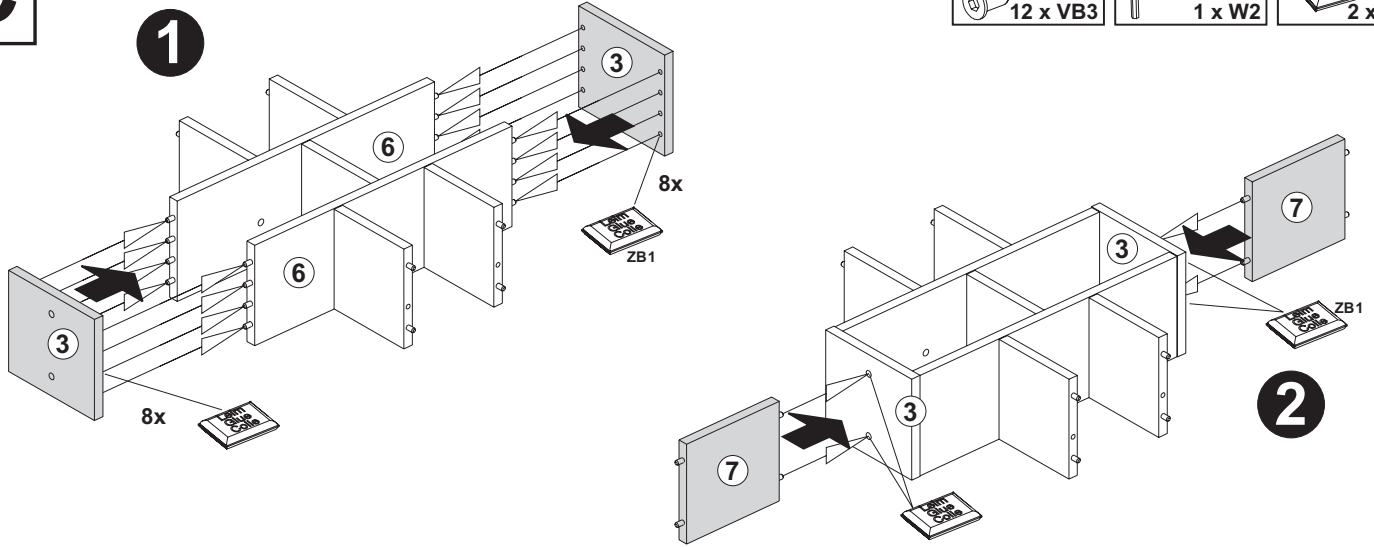
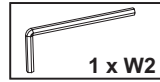
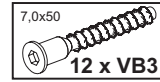

Der Untergrund der Wand ist vor der Montage auf die Eignung (Tragfähigkeit) zu prüfen. Das beiliegende Befestigungsmaterial ist nur für massives Mauerwerk geeignet!

The foundation of the wall must be checked for suitability (stability) before assembly. The enclosed mounting material is only suitable for solid brickwork.

Avant l'assemblage, il faut vérifier l'aptitude (pouvoir porteur) du fond du mur. Les matériaux de fixation ci-joints ne conviennent que pour des murs massifs!

Prima del montaggio è necessario verificare l'idoneità del fondo della parete (portata). Il materiale di fissaggio allegato è adatto solo per opere in muratura piena!

Antes del montaje, comprobar que la estructura de la pared sea adecuada (estática). El material de fijación suministrado sólo es indicado para mampostería maciza!

D

