



Montageanleitung

Notice de montage

Istruzioni di montaggio

Assembly instructions

Beschläge / Ferrures pour meubles /
Guarnizioni / Fittings

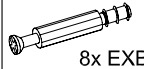
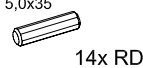
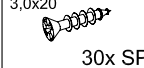
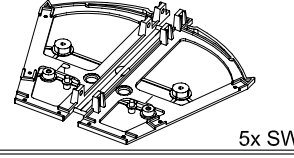
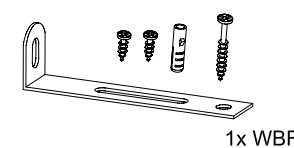
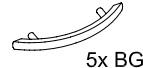
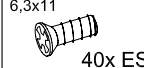
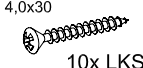
 8x EX	 8x EXB
 5,0x35 14x RD	 3,0x20 30x SP
 5x SW	
 1x WBF	
 5x BG	 6,3x11 40x ES
 4,0x30 10x LKS	

Sie benötigen: Le servono:
Vous avez besoin de: You need:

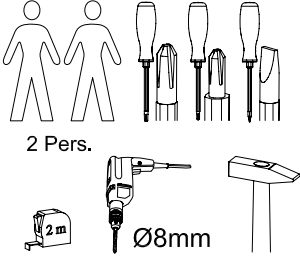

Art.-Nr. 411-005

STEP 5

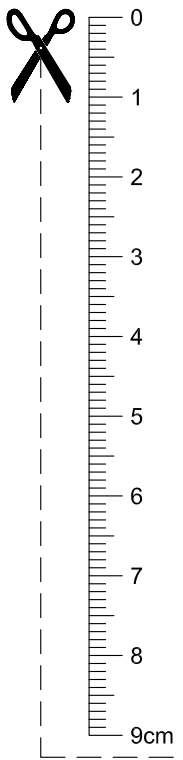
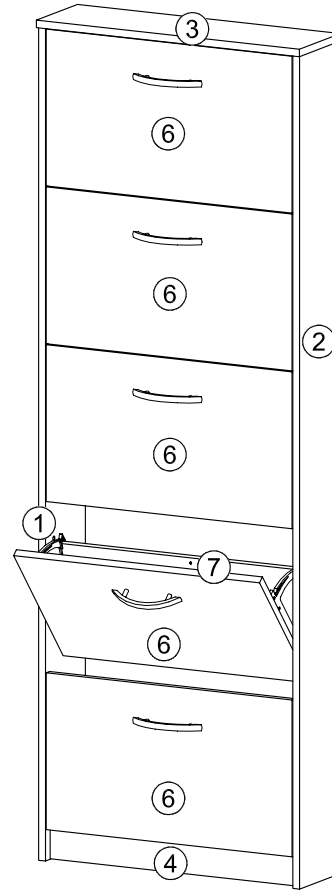

Achtung: Bei mangelhafter Montage besteht Gefahr für die Sicherheit. Wir empfehlen die Montage nur durch fachkundiges Personal.

Attenzione: Nel caso di montaggio non adeguato c'è pericolo di sicurezza. Consigliamo di far eseguire il montaggio esclusivamente da parte di personale esperto.



Attention: En cas de montage incorrect, il y a risque pour la sécurité. Nous recommandons de ne faire effectuer le montage que par du personnel qualifié.

Warning: Deficient assembly causes safety risks. We recommend having the assembly done only by qualified personnel.

Teile / Pieces / Pezzi / Article

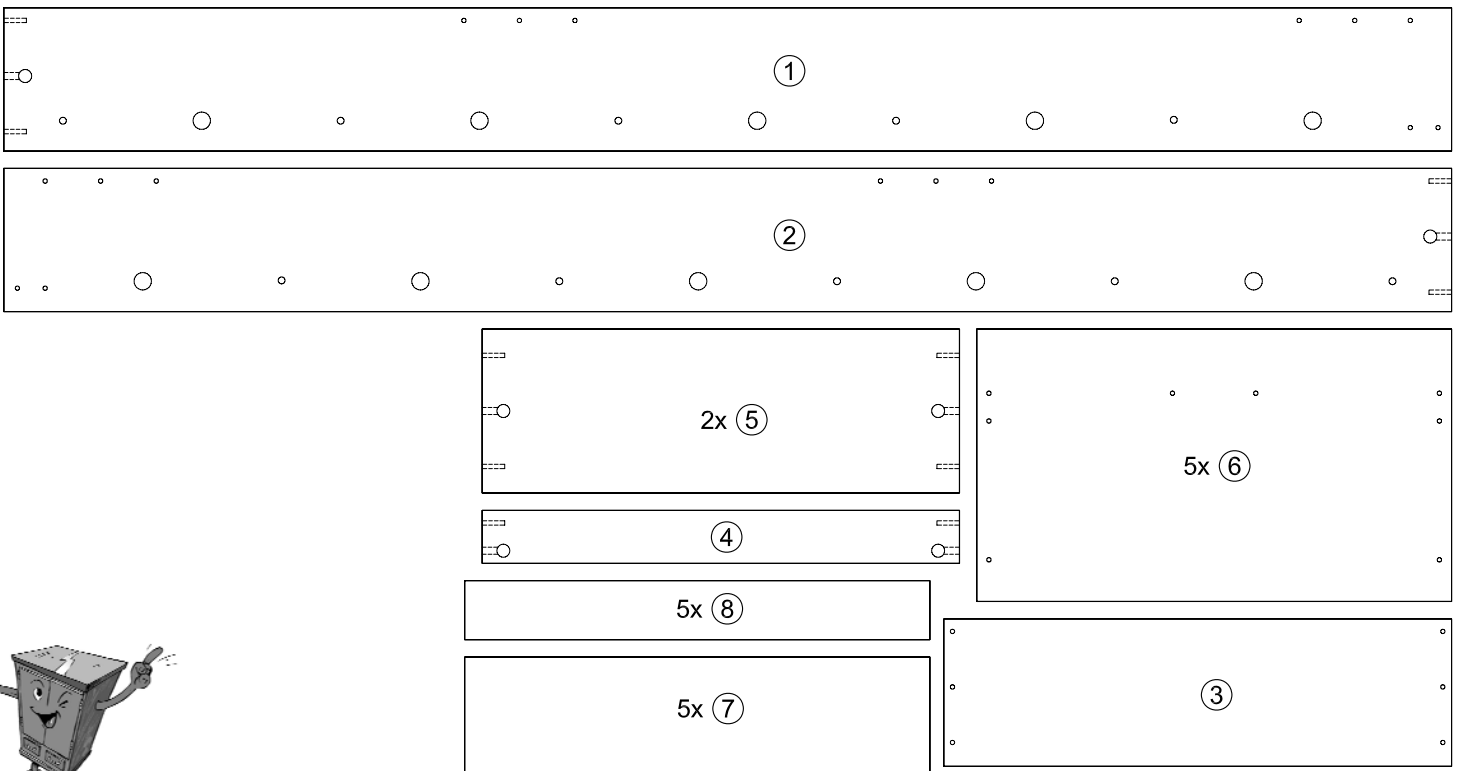

A

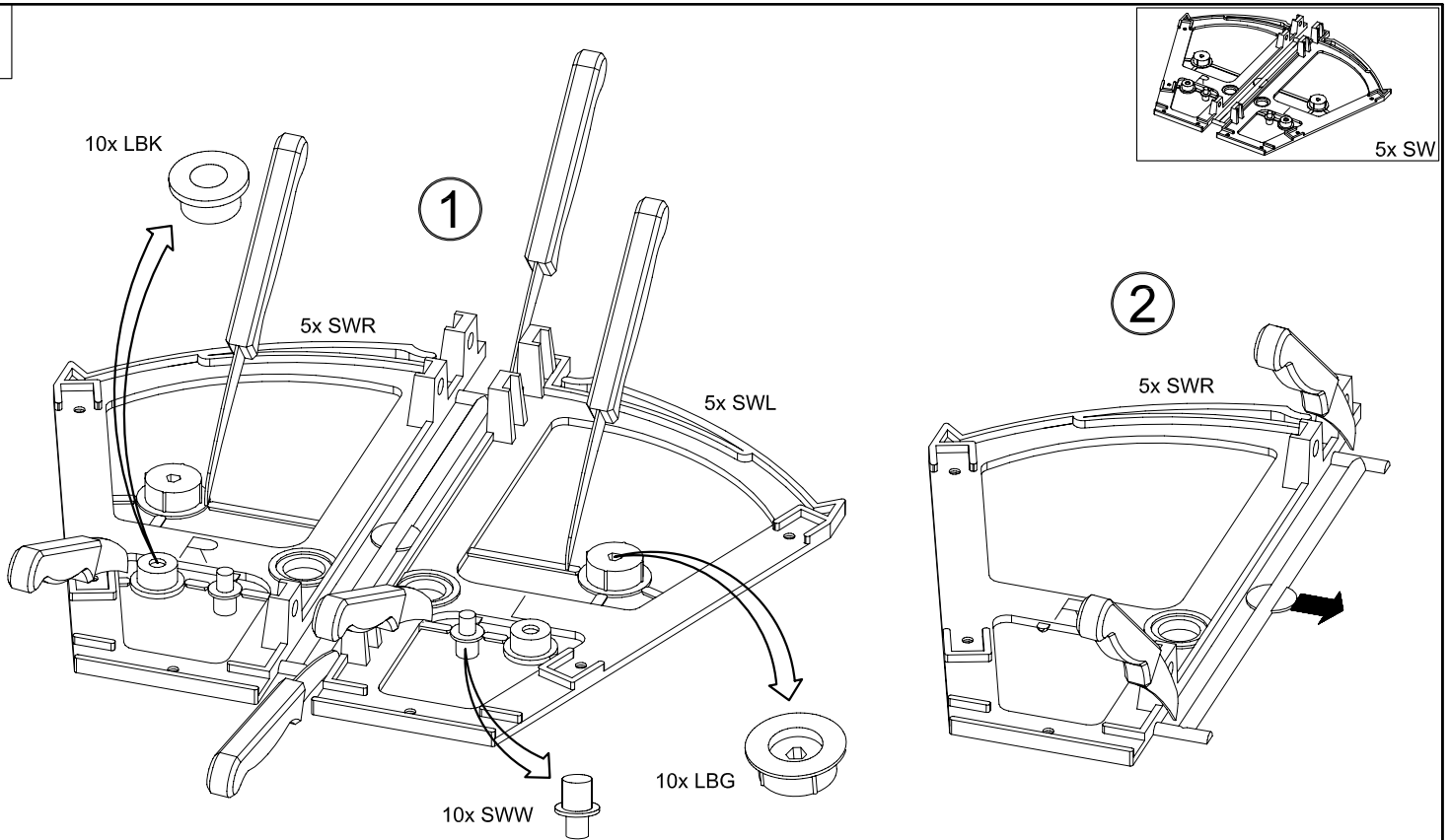

B

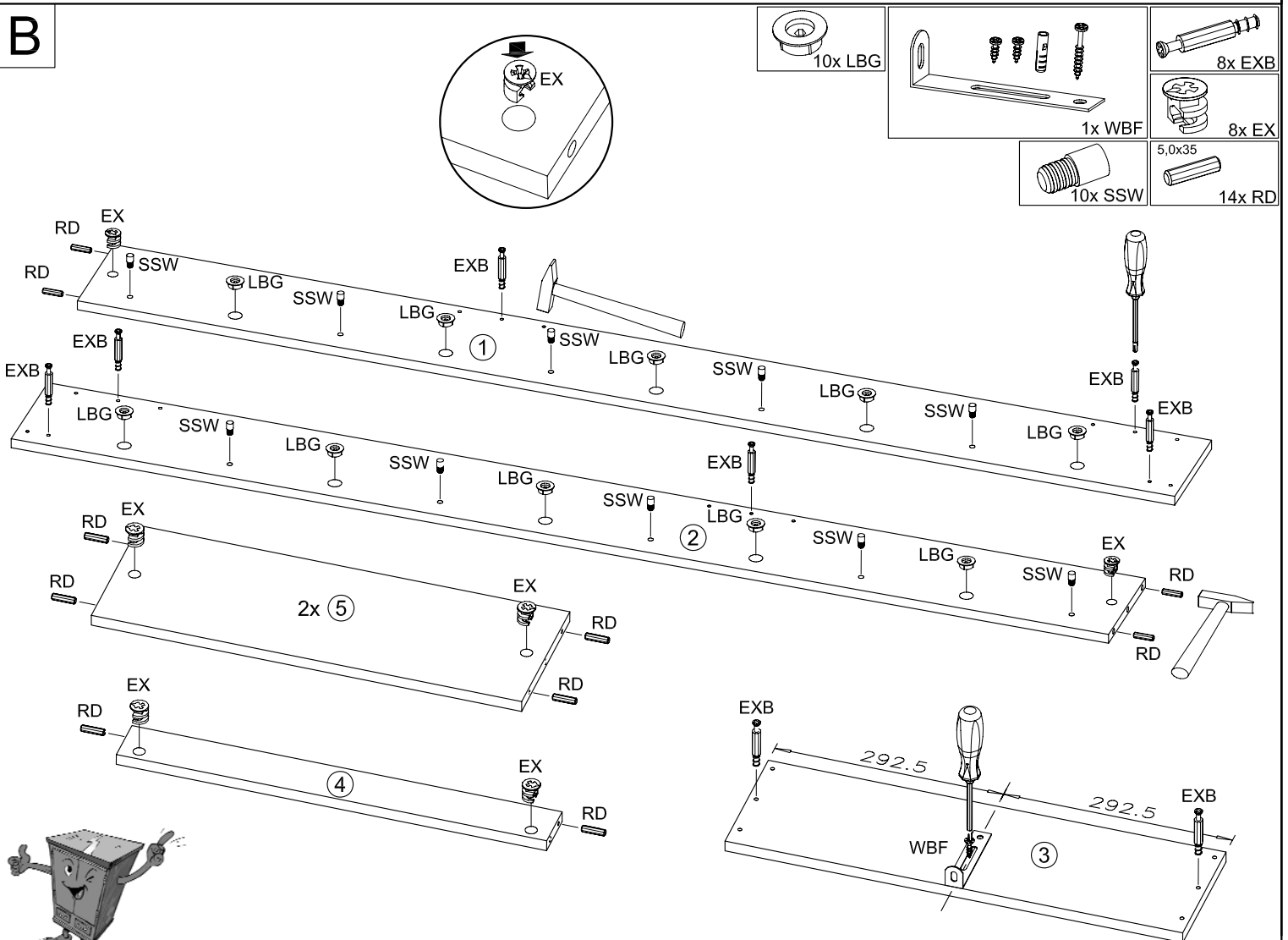

STEP 5

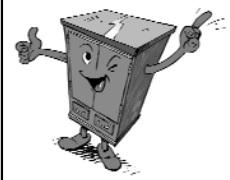
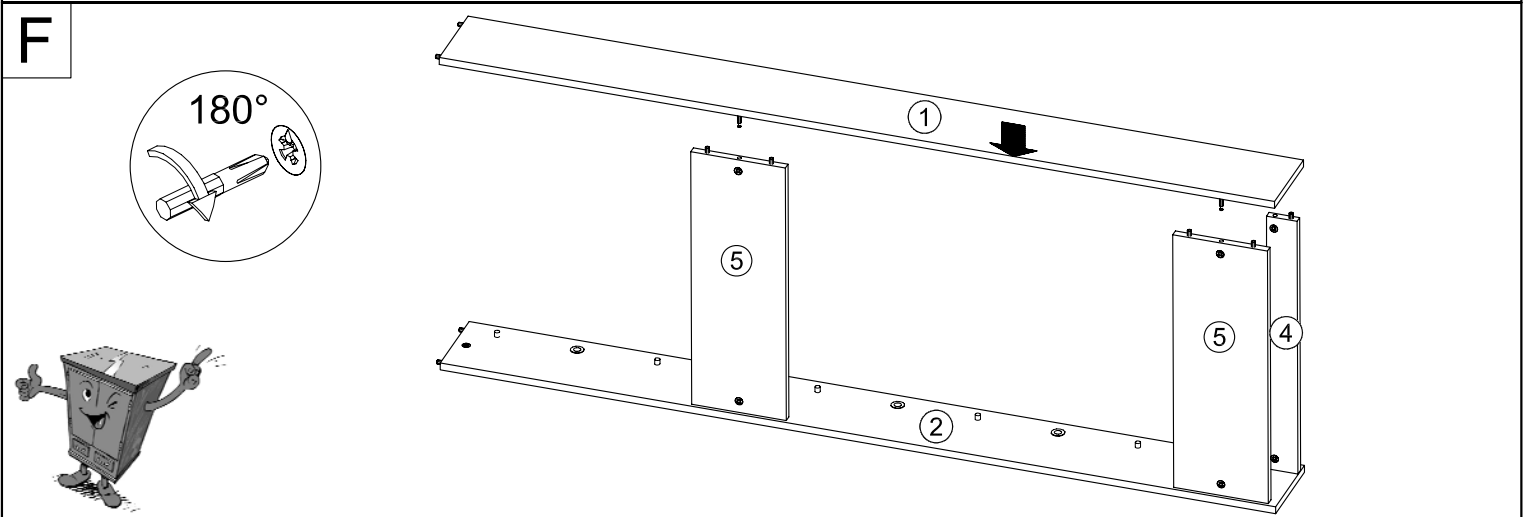
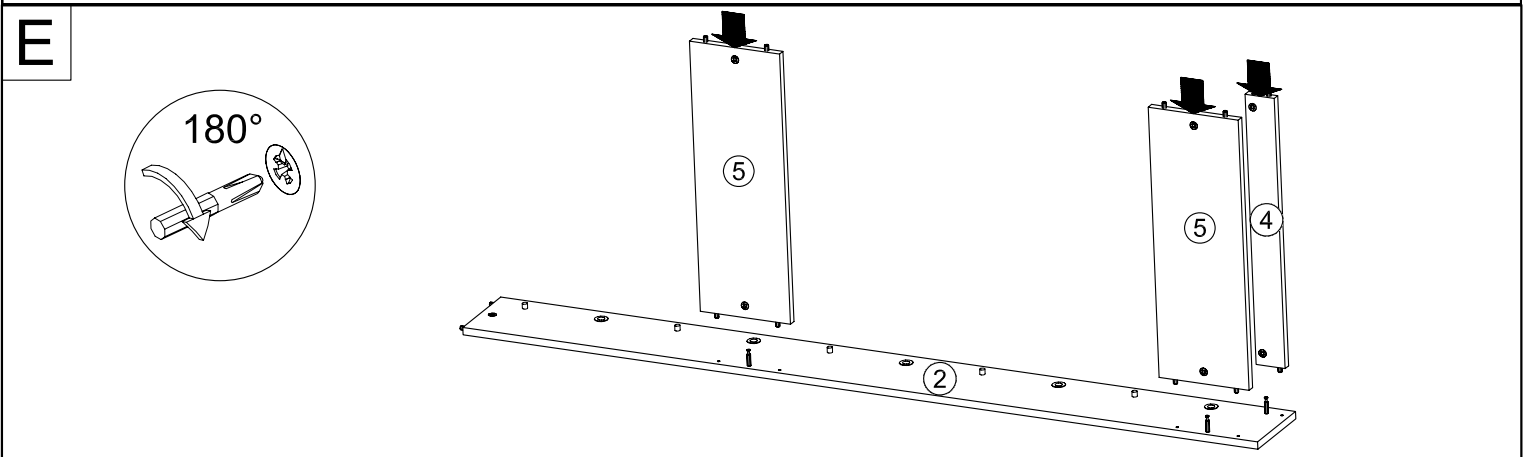
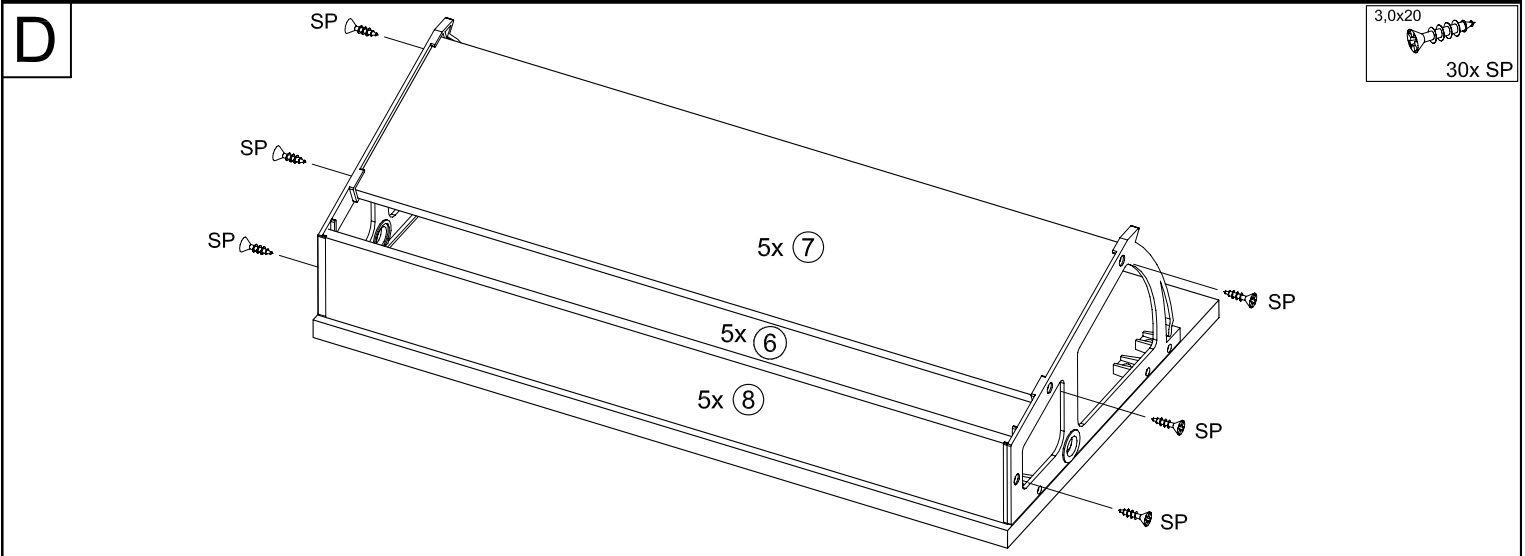
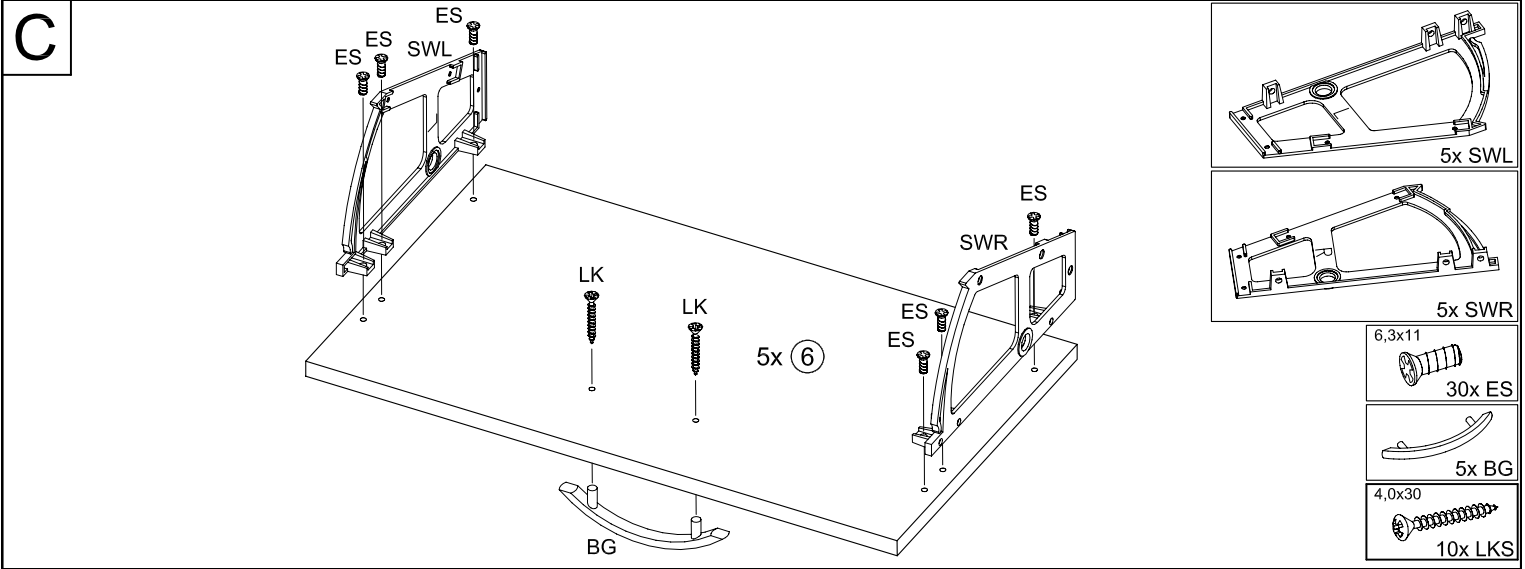

G

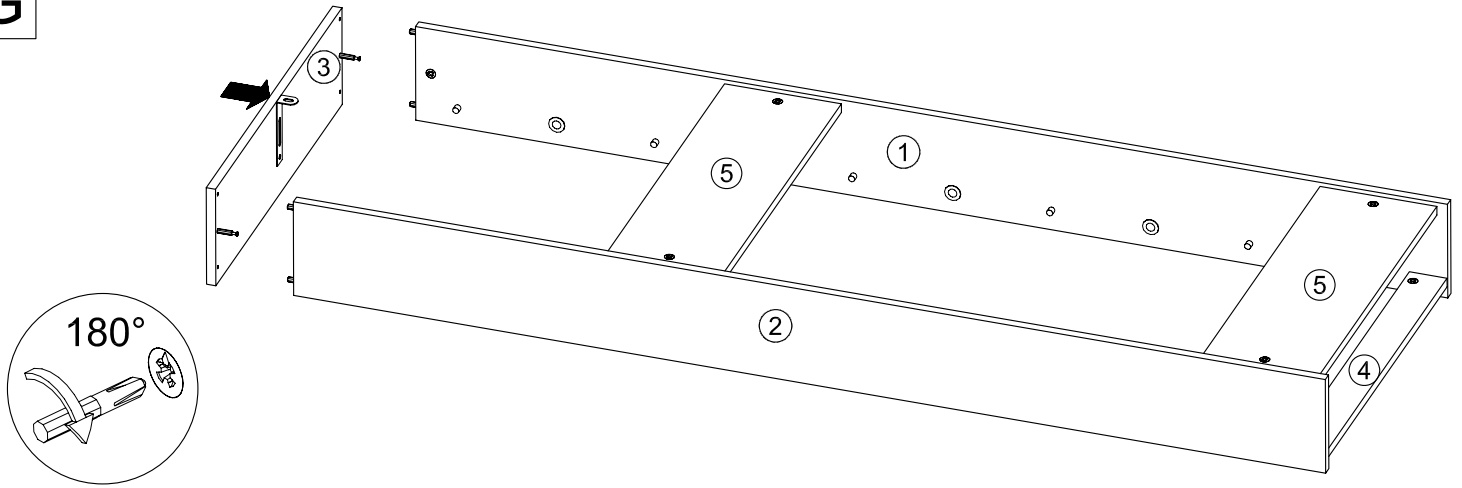

H

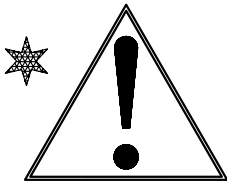

Bei Verbindungsmittel für die Wandbefestigung ist das Trägermaterial auf Eignung zu Prüfen.

En cas de moyens de liaison pour la fixation murale, il faudra vérifier l'aqtitude du matériel de support.

Nel caso di mezzi di connessione per il fissaggio della parete il materiale portante deve essere esaminato in vista della sua idoneità.

In case of connective devices for the wall mounting, the supporting material must be checked for suitability.

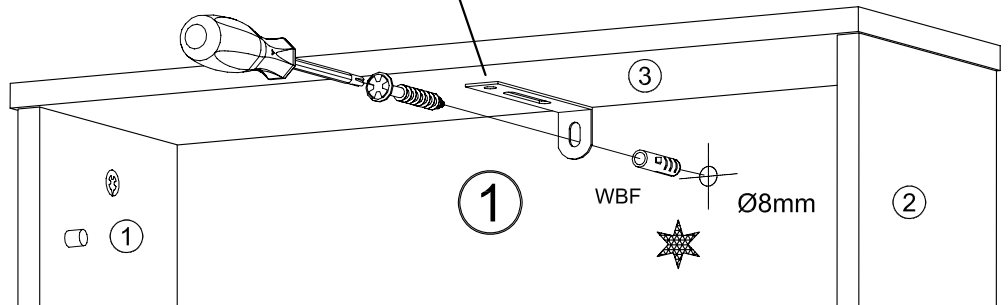
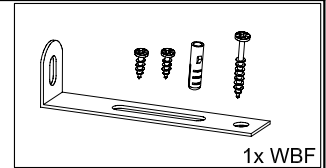
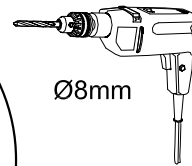
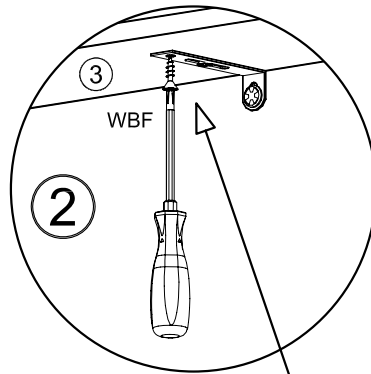

I

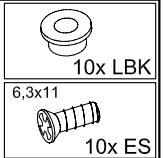
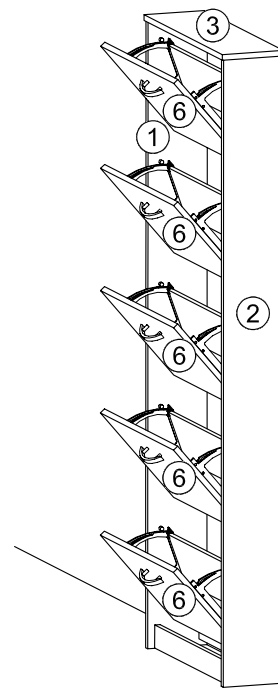
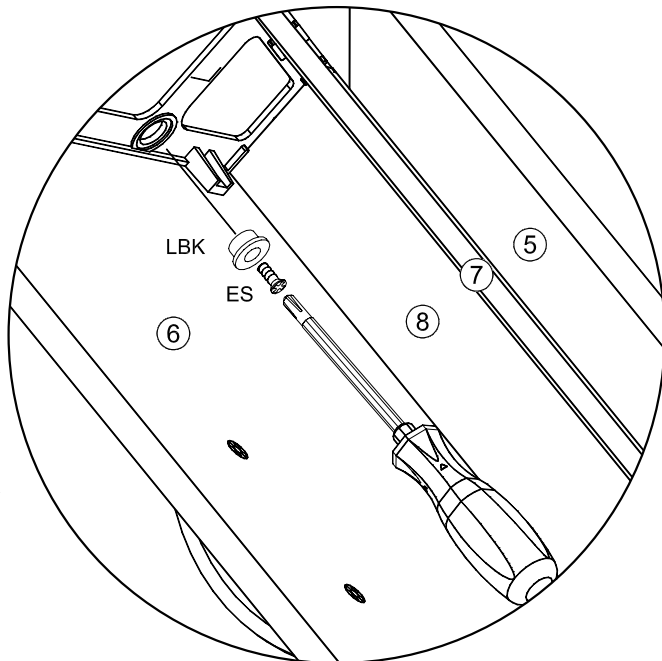

Bitte nur mit einem Staubtuch oder einem feuchten Lappen reinigen. Keine scheuernden Putzmittel verwenden!

Ne nettoyer qu'avec un chiffon à poussière ou un chiffon humide. Ne pas utiliser de produit à récurer!

Per favore pulire solo con un panno per rimuovere polvere o con uno straccio umido. Non usare detergenti abrasivi!

Please do only clean with a duster or adamp cloth. Do not use any scouring agents!