

# Modell: CITY / GIRON 52

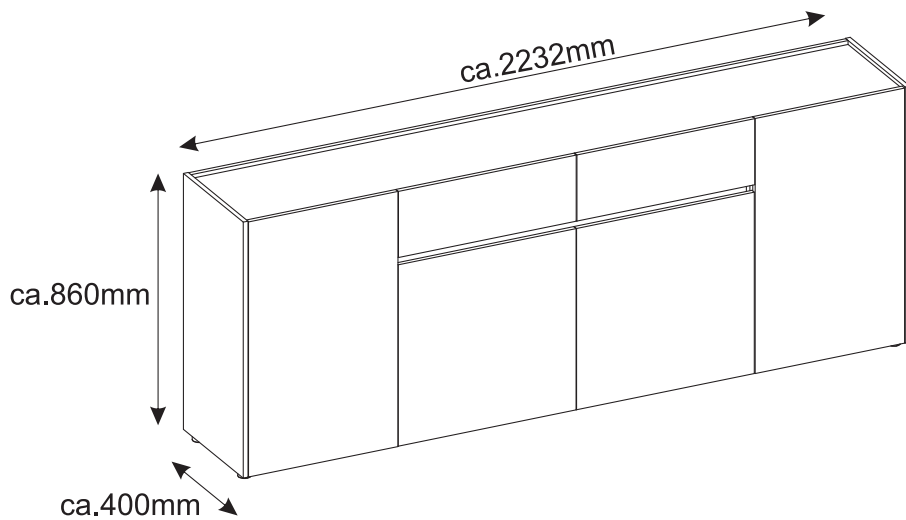

- ⓓ **Montageanleitung**
- ⓃⓁ **Handleiding voor de montage**
- ⓉⓇ **Montaj talimatı**
- ⓕ **Notice de montage**
- ⒸⓏ **Montážní návod**
- ⓗⓤ **Szerelési útmutató**
- ⓖⓔ **Assembly instructions**
- ⓅⓁ **Instrukcja montażu**
- Ⓡⓤ **Инструкция по монтажу**
- ⓔⓐ **Istruzioni di montaggio**
- ⓈⓀ **Návod na montáž**
- Ⓡⓞ **Instrucțiuni de montaj**
- ⓔⓈ **Instrucciones de montaje**
- ⓉⓇ **Montaj Talimatı**

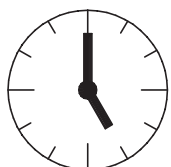
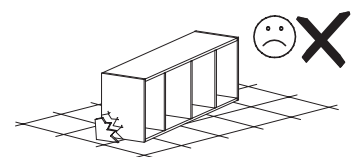
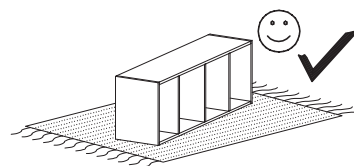
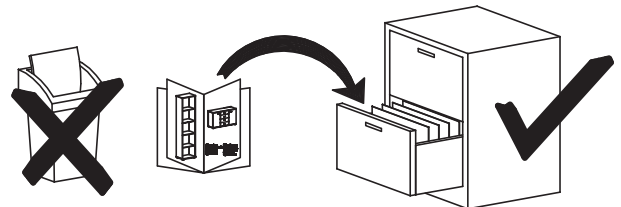
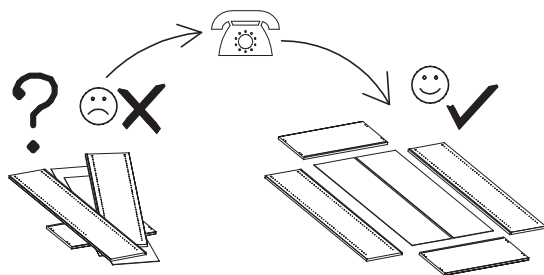
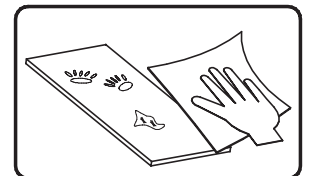
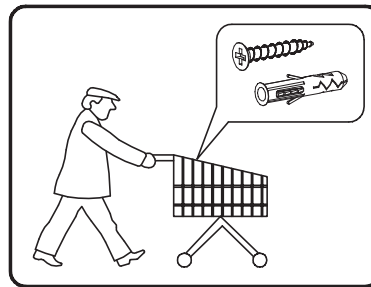
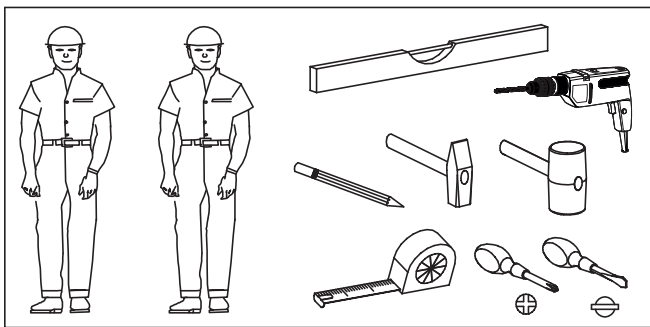

2,5h

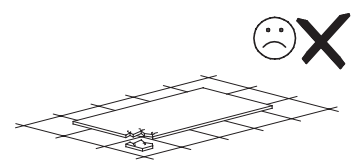
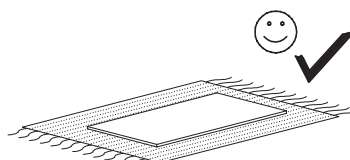

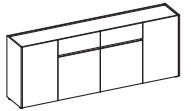





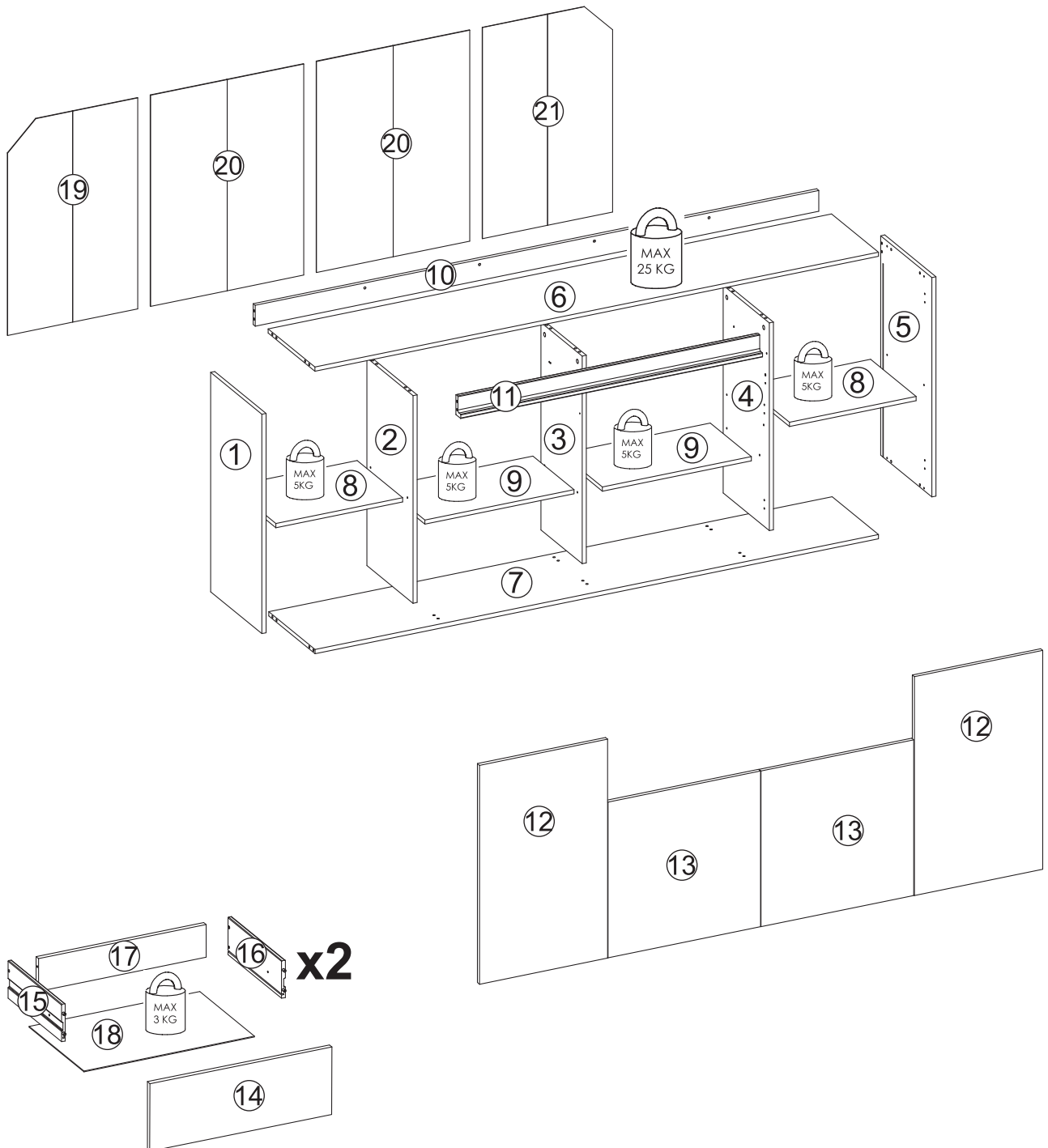

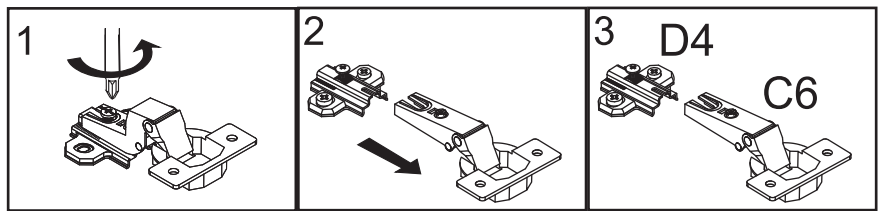
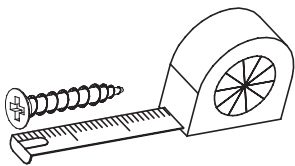
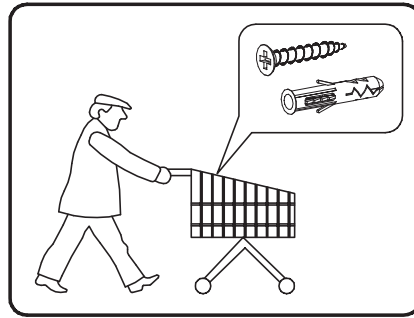
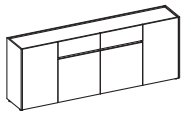



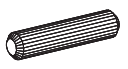

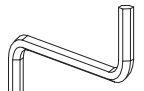



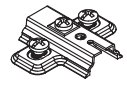
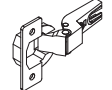

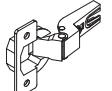
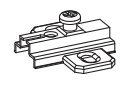

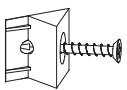
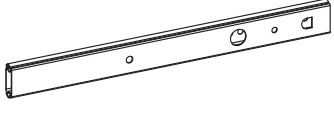

nr	L[mm]	B[mm]	T[mm]	Menge	Colli
1	840	400	16	1	1/3
2	795	361	16	1	1/3
3	795	322	16	1	3/3
4	795	361	16	1	1/3
5	850	400	16	1	1/3
6	2200	366	16	1	3/3
7	2200	362	16	1	3/3
8	495	356	16	2	1/3
9	582	321	16	2	3/3
10	2200	80	16	1	3/3
11	1178	77	38	1	3/3

nr	L[mm]	B[mm]	T[mm]	Menge	Colli
12	837	500	16	2	1/3
13	565	595	16	2	1/3
14	595	217	16	2	2/3
15	350	120	12	2	2/3
16	350	120	12	2	2/3
17	548	105	12	2	2/3
18	559	358	3	1	1/3
19	808	508	3	1	1/3
20	808	598	3	2	1/3
21	808	508	3	1	1/3

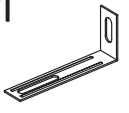

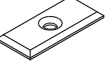
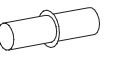

<b>B1</b>  ø8x35 x26	<b>B2</b>  ø6x30 x4	<b>A1</b>  ø7x50 x14	<b>W2</b>  x1	<b>I7</b>  x10
<b>K1</b>  x16	<b>K10</b>  x16	<b>D4</b>  x4	<b>C6</b>  x4	<b>G48</b>  6,3x13 x8
<b>C7</b>  x4	<b>D5</b>  x4	<b>G34</b>  3,5x16 x18	<b>G47</b>  6,3x13 x8	<b>G49</b>  4x16 x18
<b>F13</b>  x1	<b>N1</b>  M4x9 x4	<b>I1</b>  x6	<b>H5</b>  x4	
<b>W1</b>  x1	<b>M11</b>  x2	<b>G50</b>  3x20 x51	<b>P10</b>  x7	<b>G36</b>  4x30 x7
<b>Z6</b>  x15	<b>F2</b>  x16			

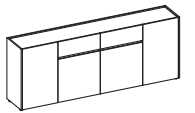

I

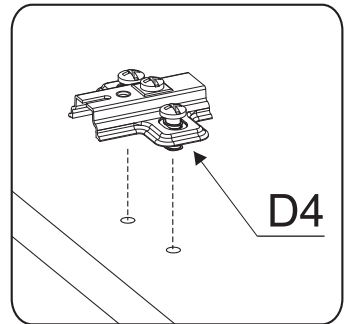
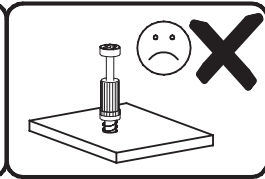
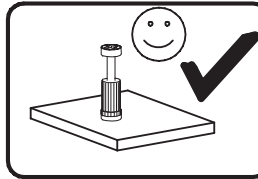
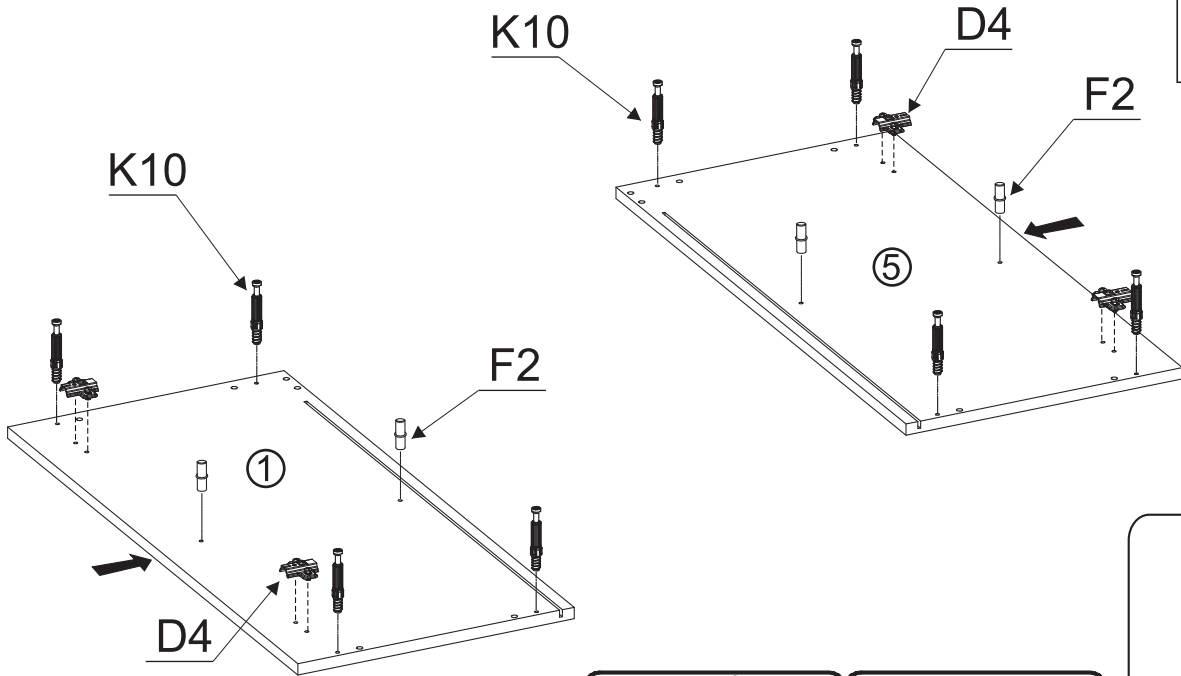
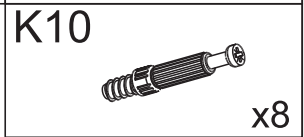
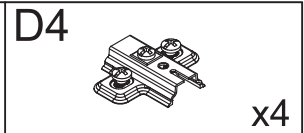
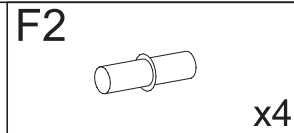



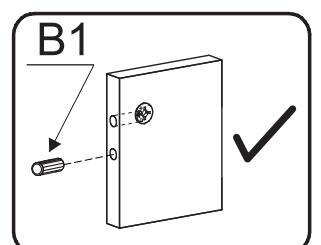
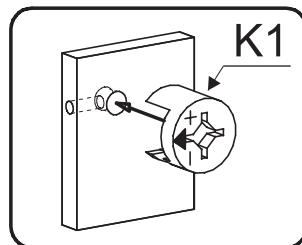
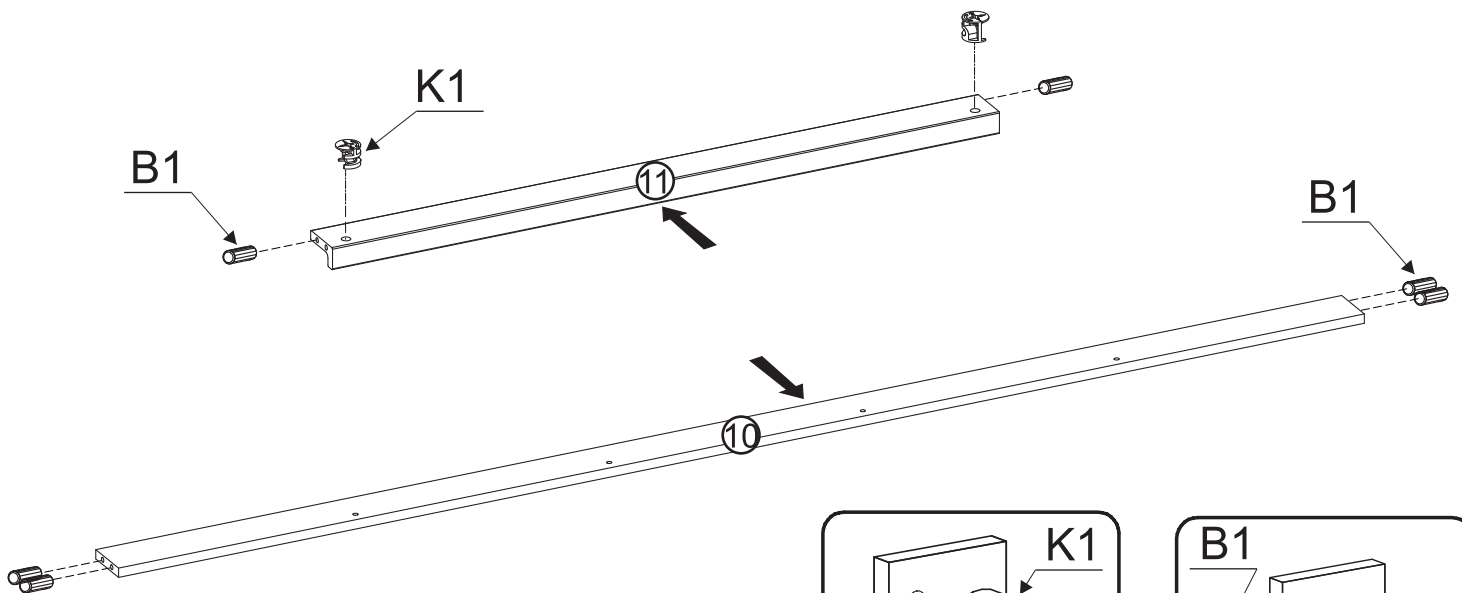
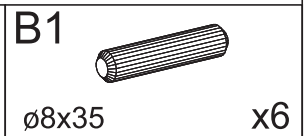

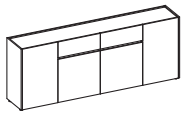

II



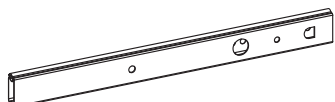

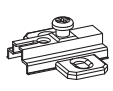



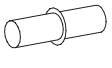

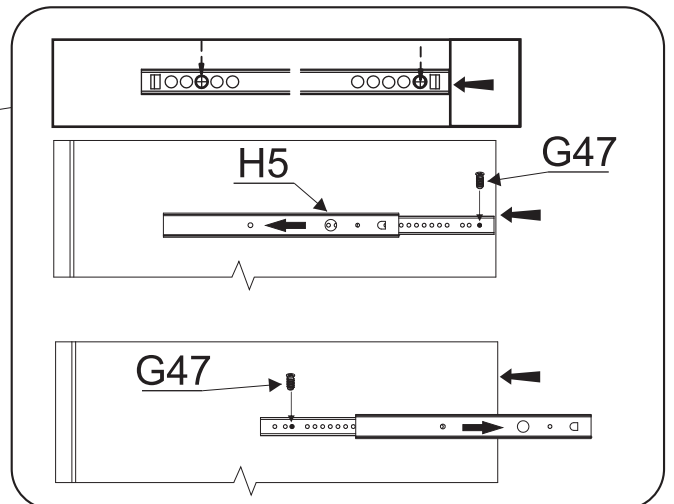
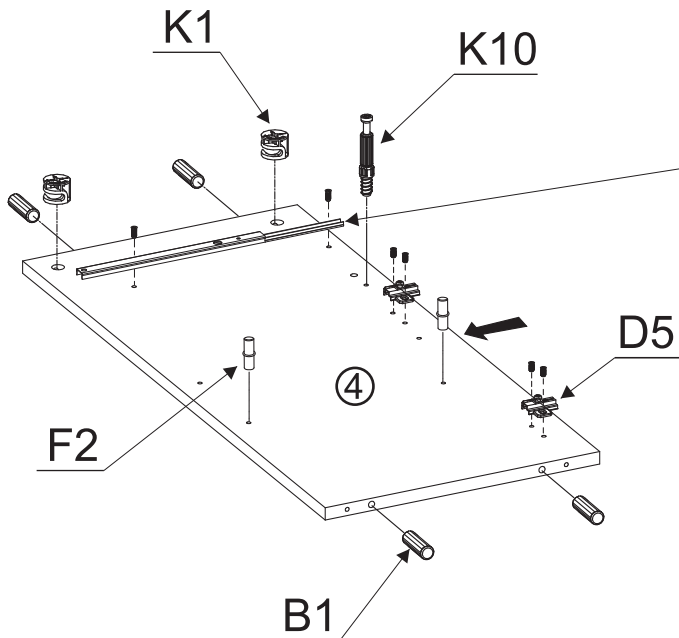
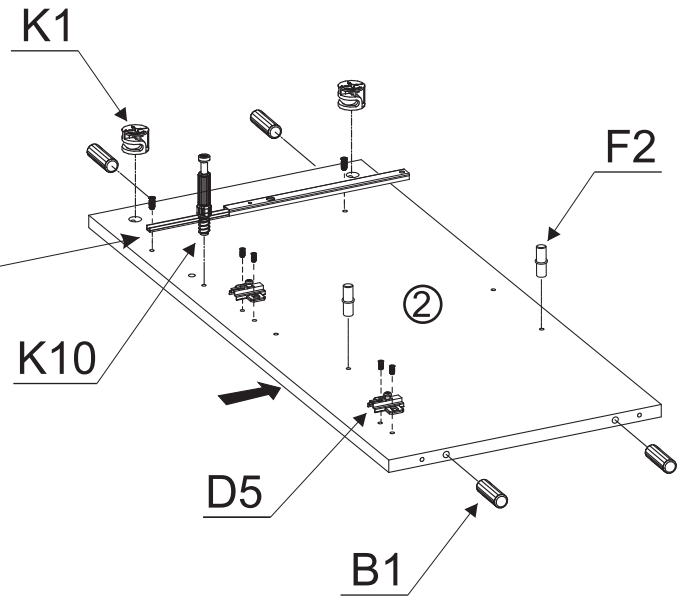
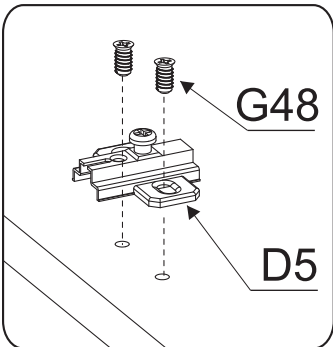
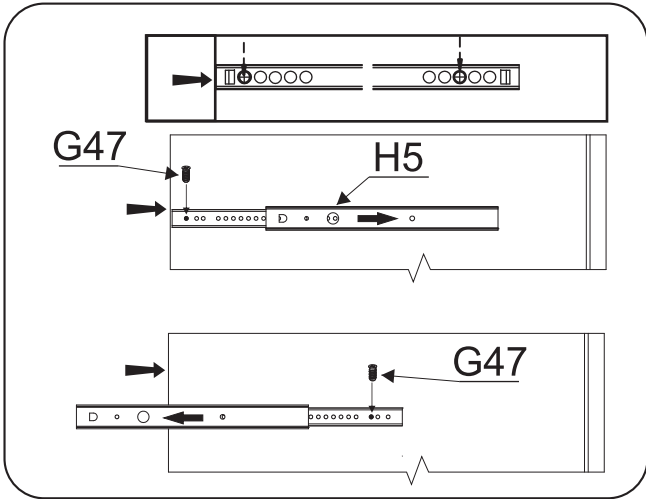

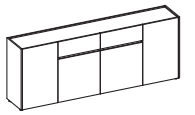
III

<p><b>G48</b> 6,3x13 x8</p> 	<p><b>H5</b> x2</p> 	<p><b>K1</b> x4</p> 
<p><b>D5</b> x4</p> 	<p><b>K10</b> x2</p> 	<p><b>G47</b> 6,3x13 x4</p> 
		<p><b>B1</b> ø8x35 x8</p> 
		<p><b>F2</b> x4</p> 



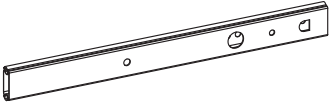

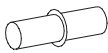
IV

F13  x1	H5  x2	K1  x2
G49  4x16 x1	F2  x4	G47  6,3x13 x4
	B1  ø8x35 x4	

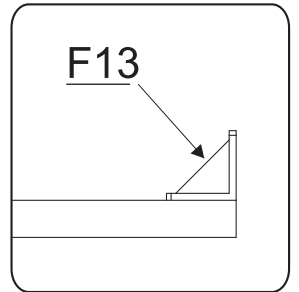
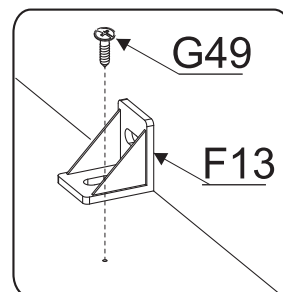
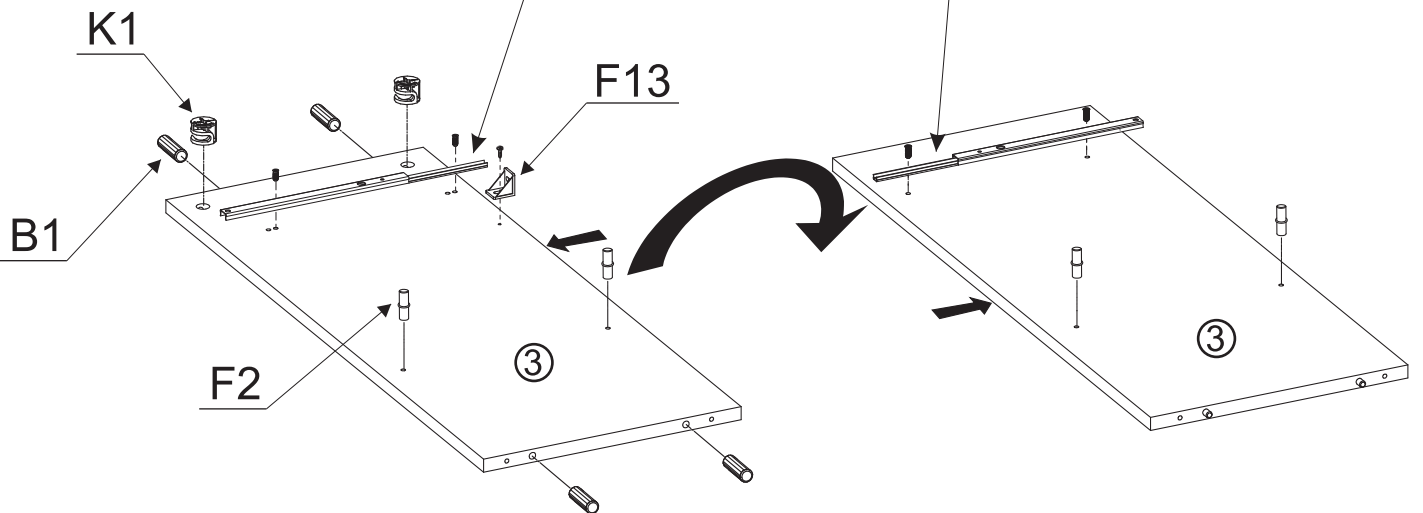
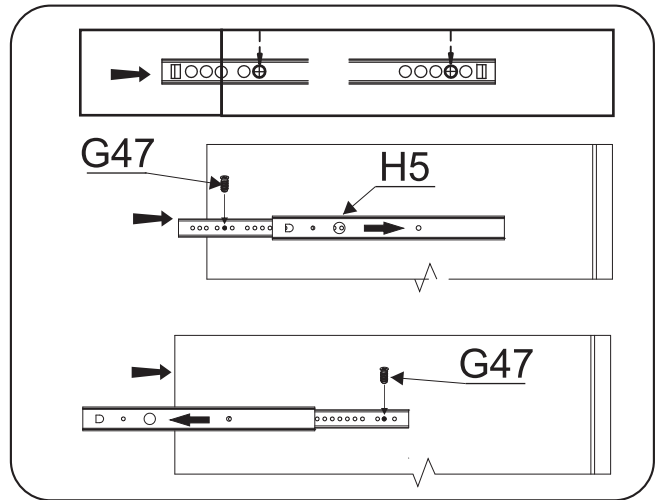
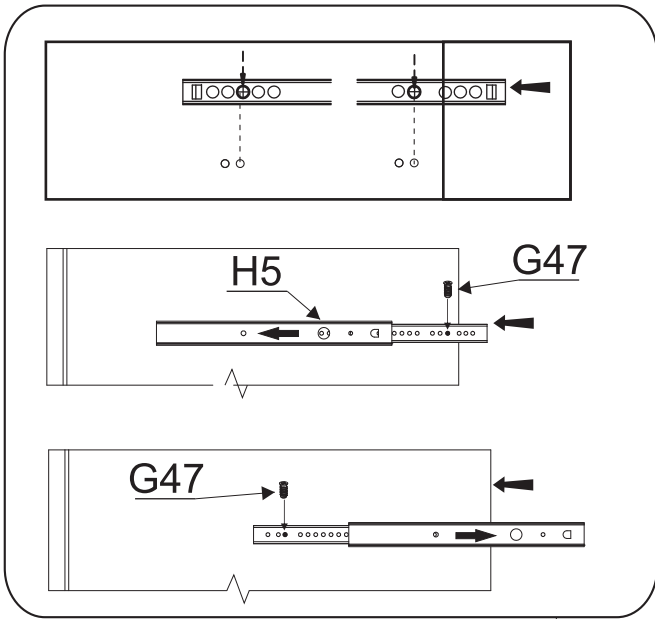

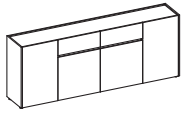

V

B1



ø8x35

x8

K1



x8

K10



x6

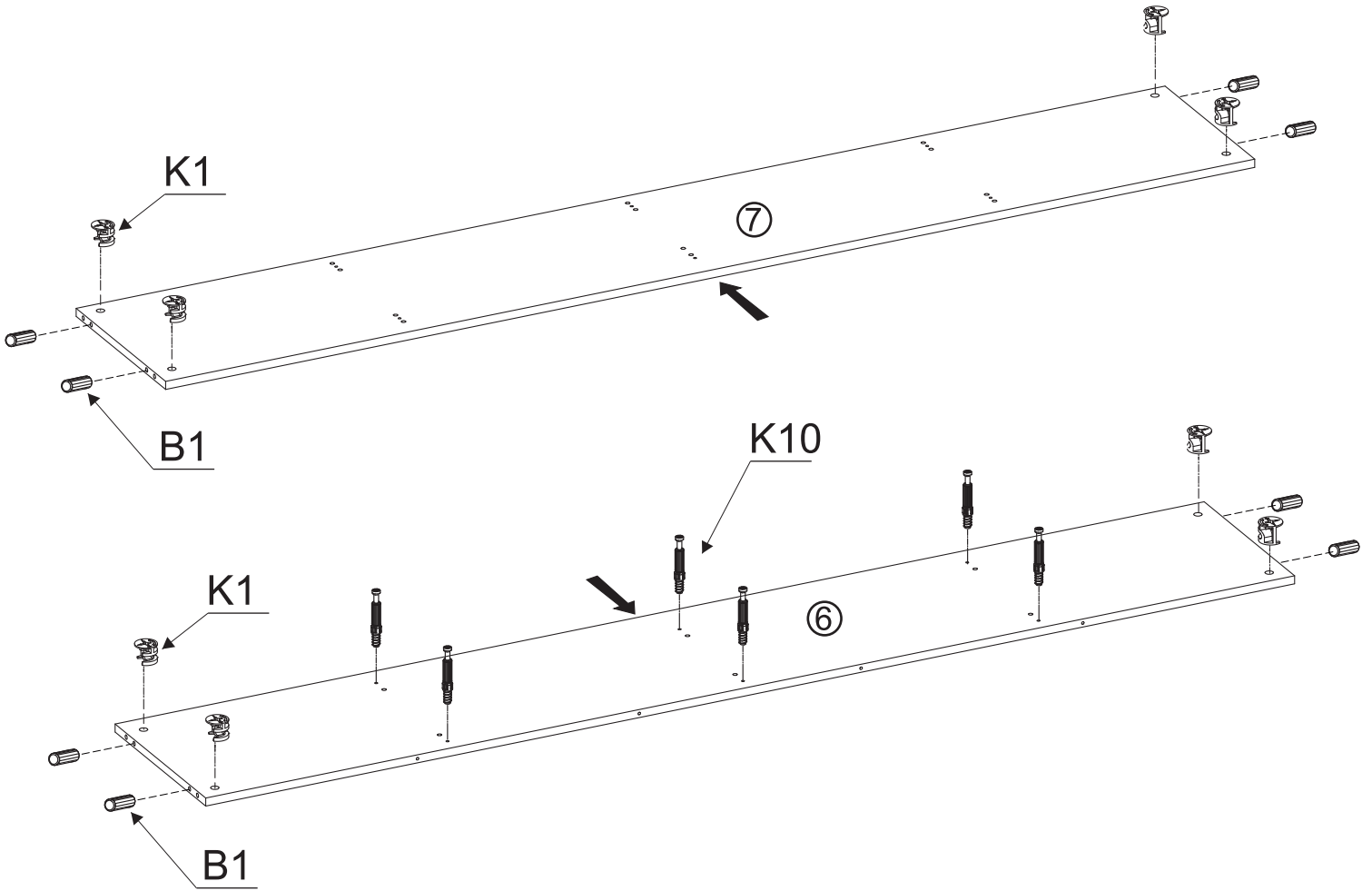

VI

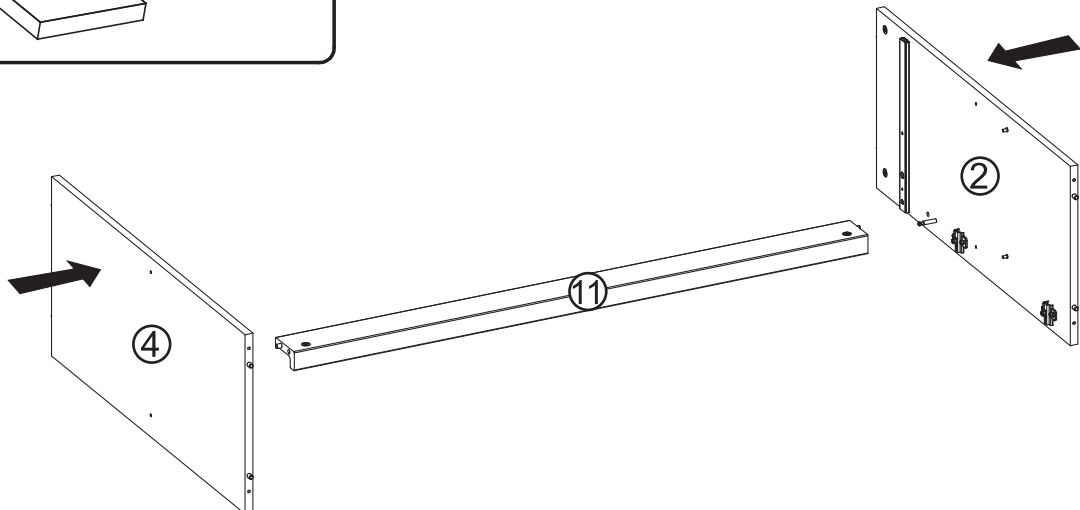
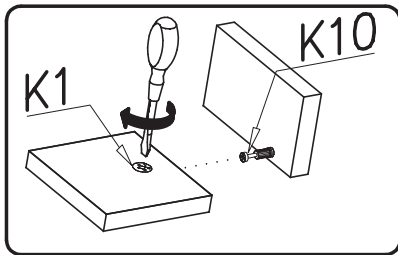

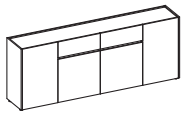

# VII

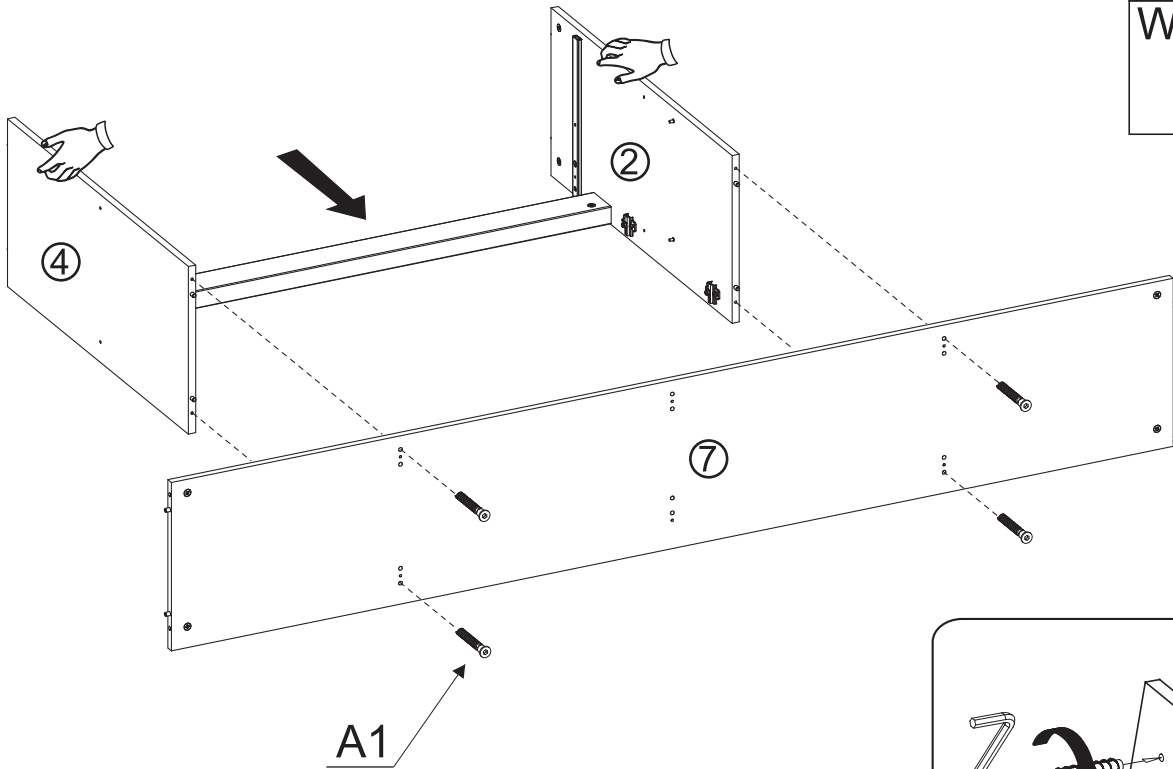

A1		x4
o7x50		
W2		x1

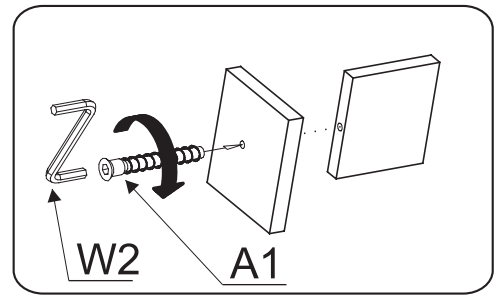

# VIII

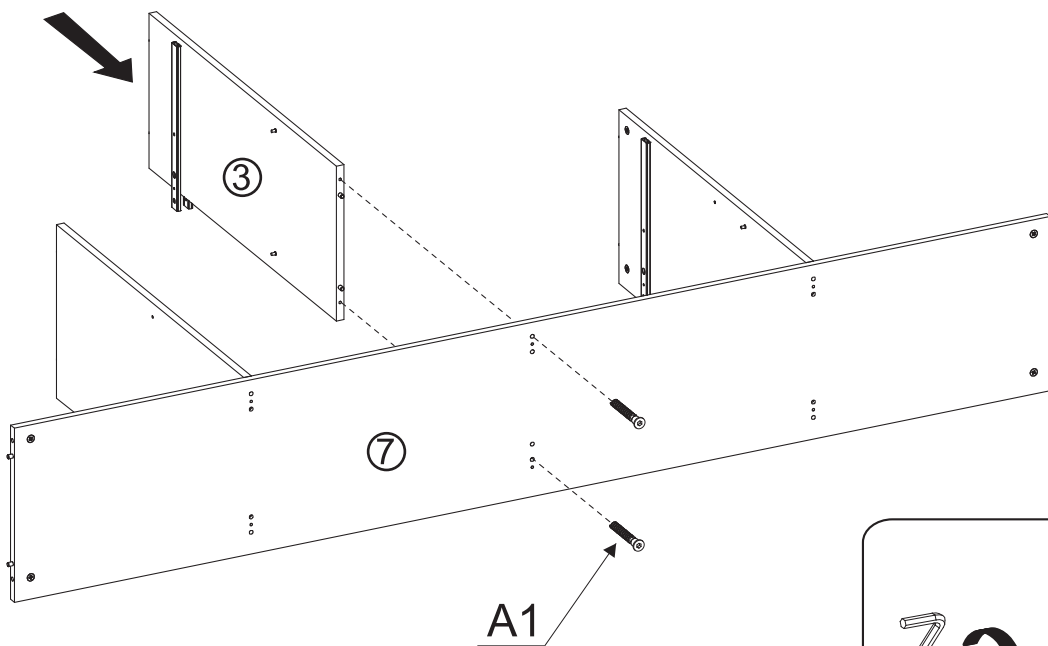

A1		x2
ø7x50		
W2		x1

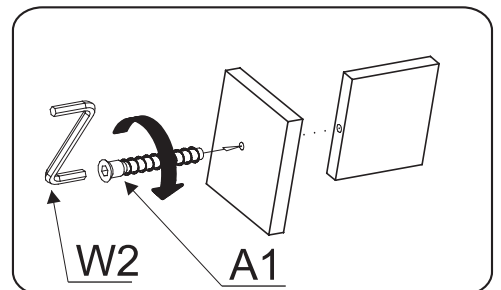

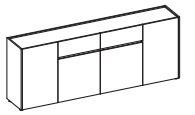

# IX

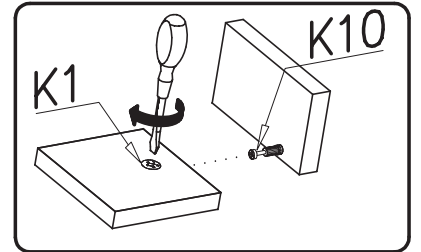
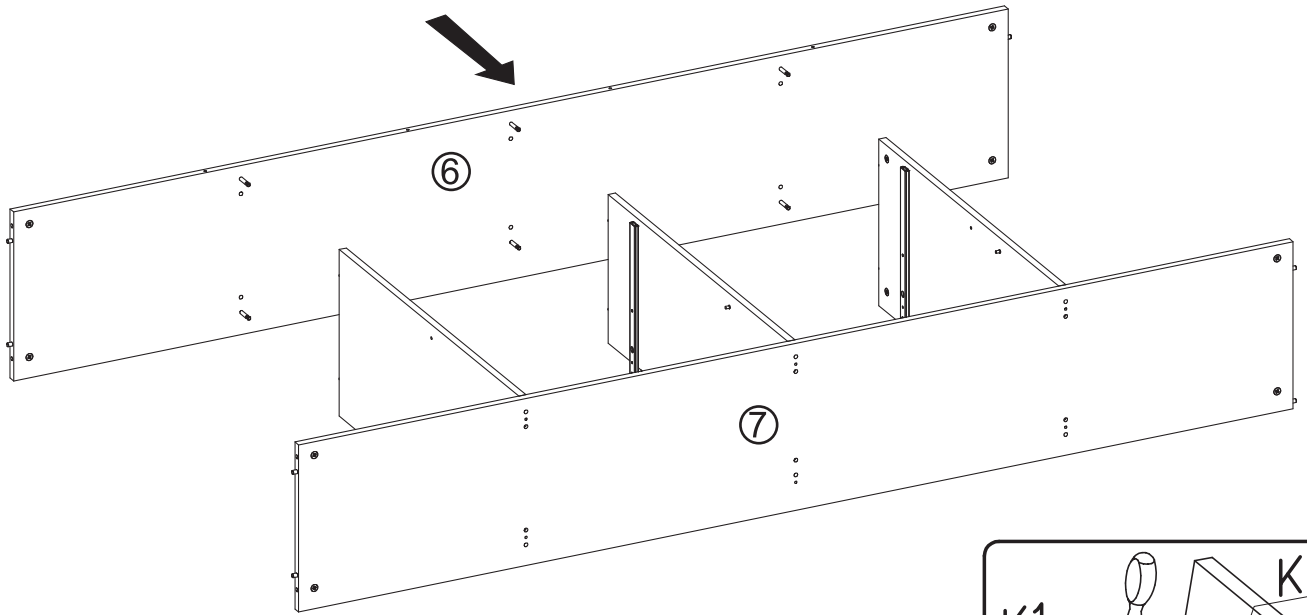

# X

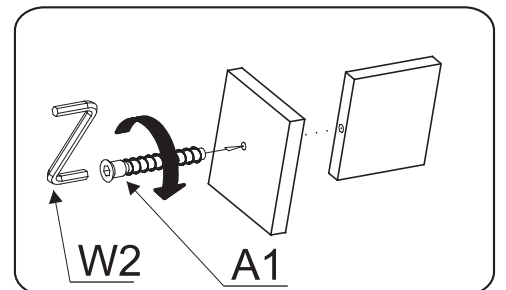
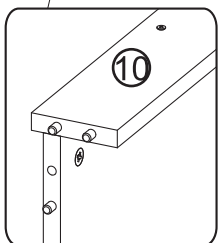
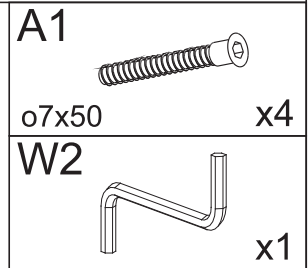
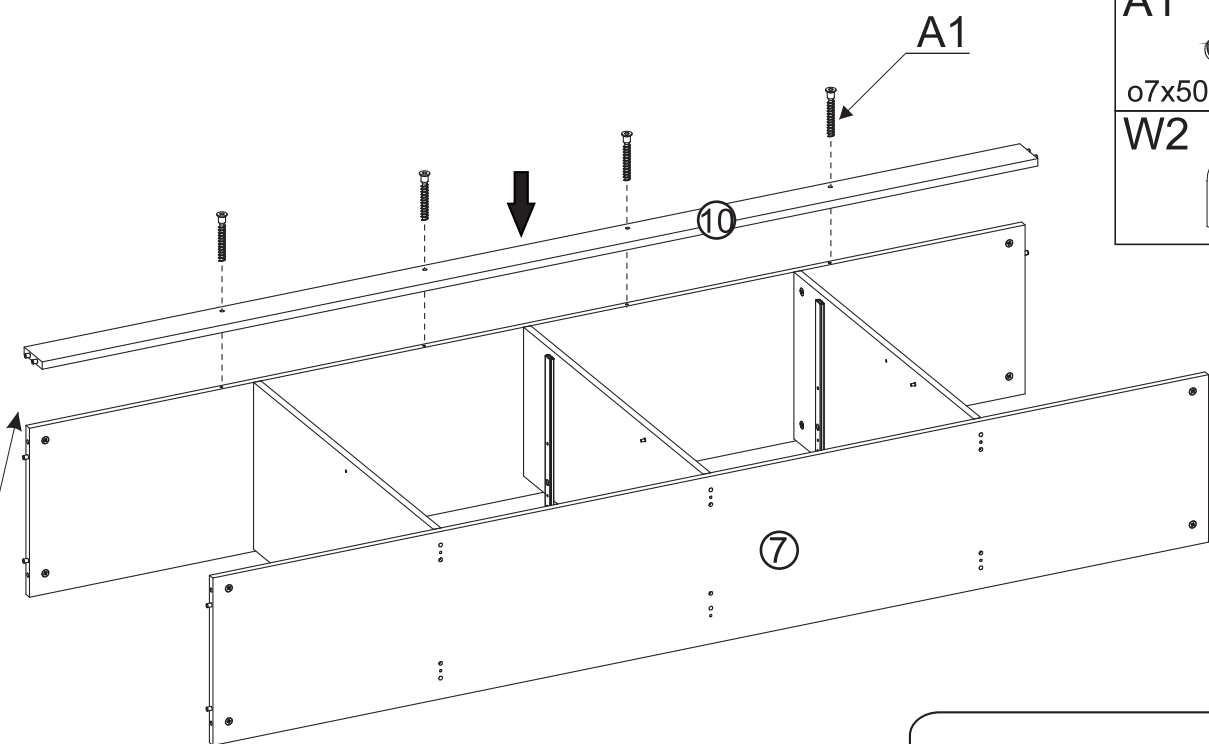

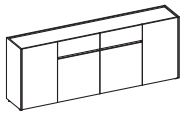

XI

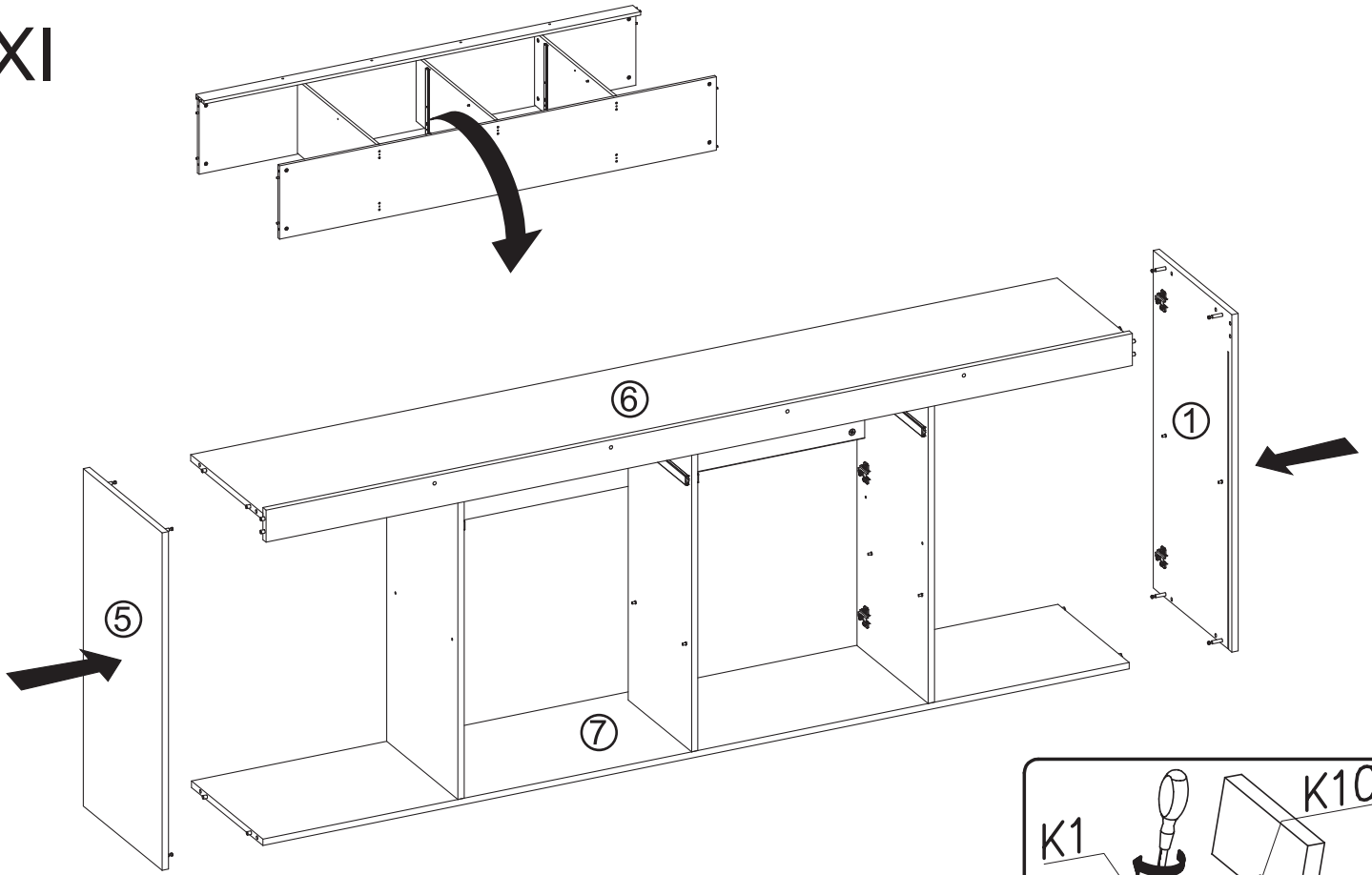

XII

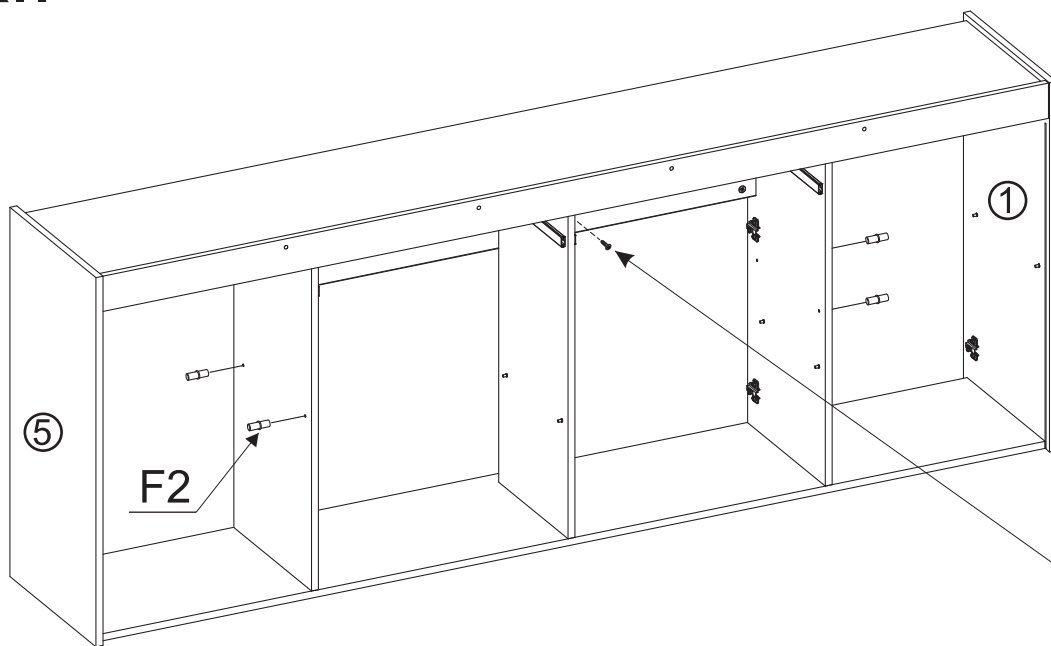

G49



4x16

x1

F2

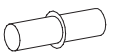

x4

G49

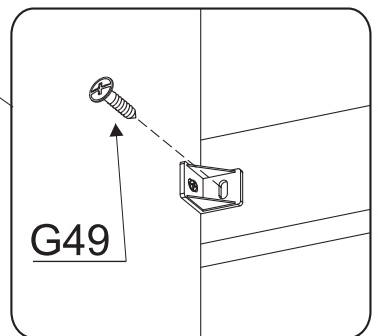

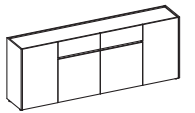

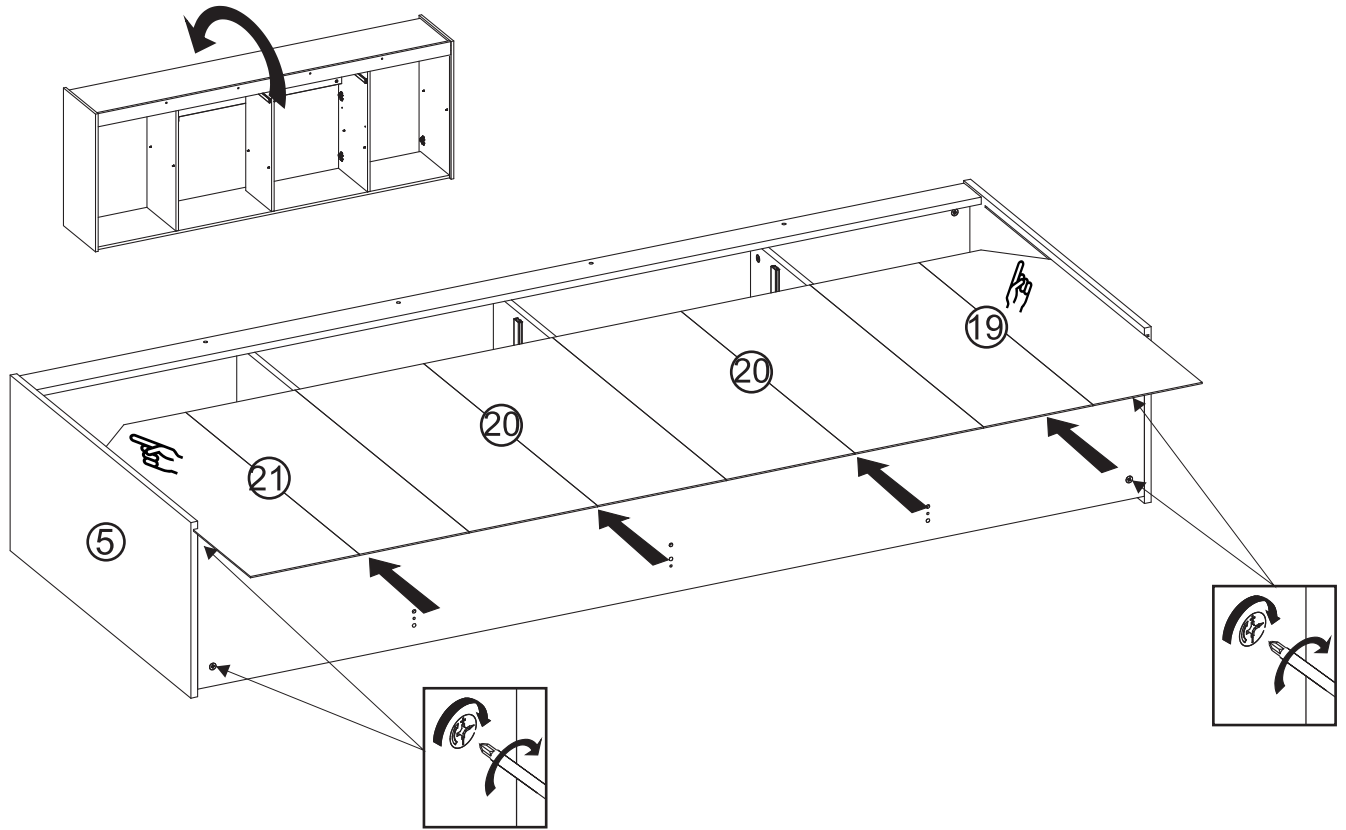

# XIII

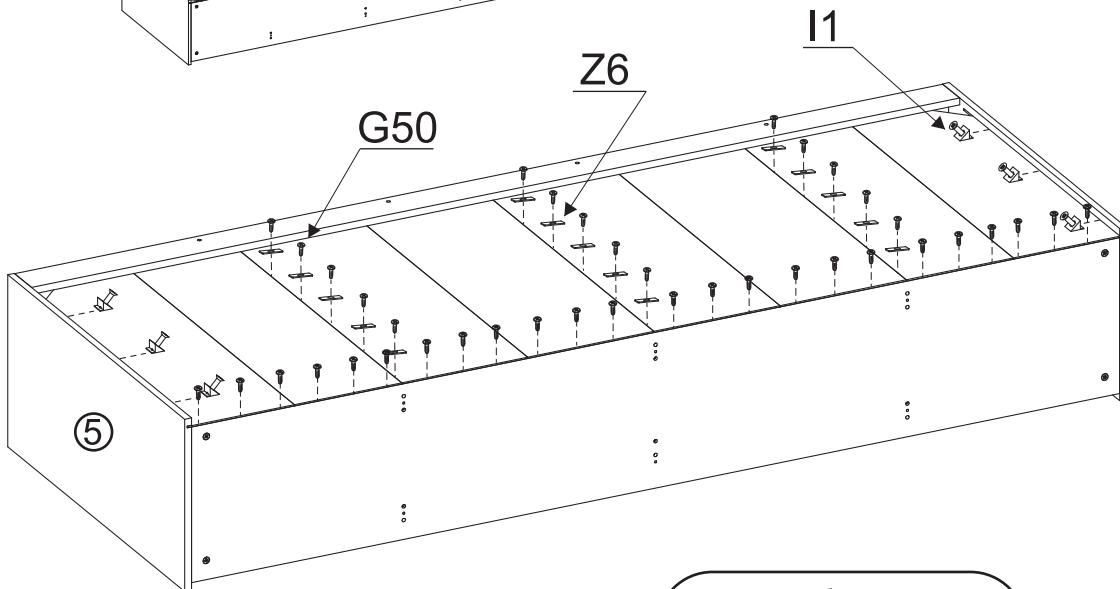
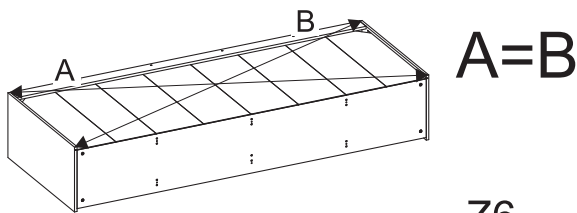

# XIV

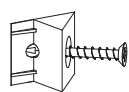
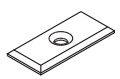

- G50  x39
- 3x20
- I1  x6
- Z6  x15

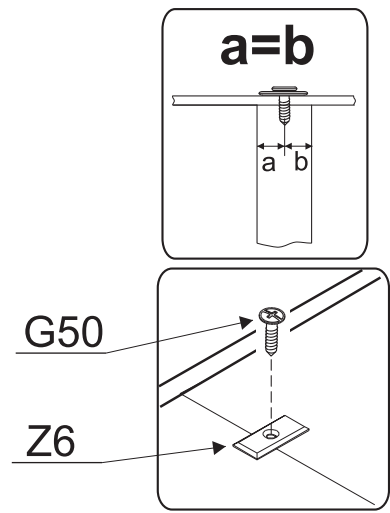
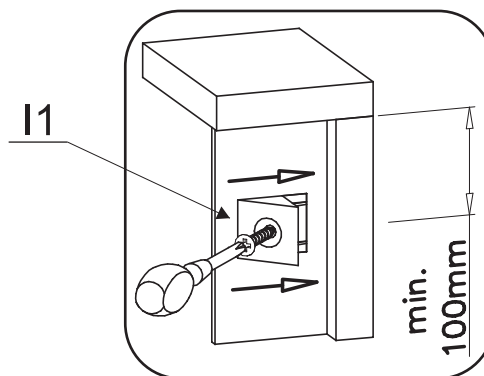
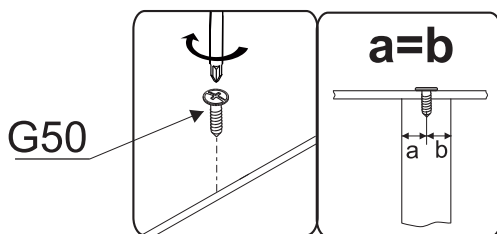

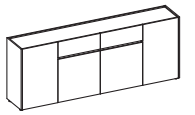

XV

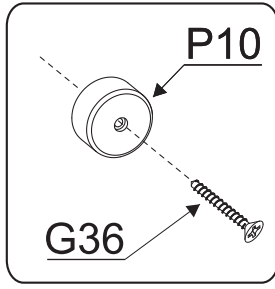

P10

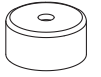

x7

G36



4x30

x7

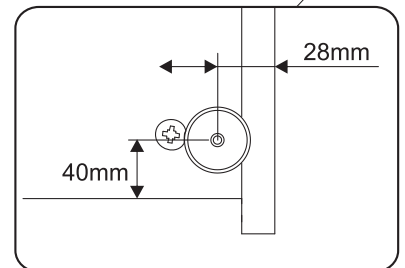
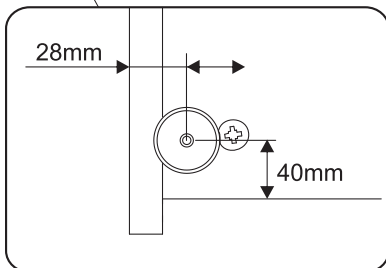
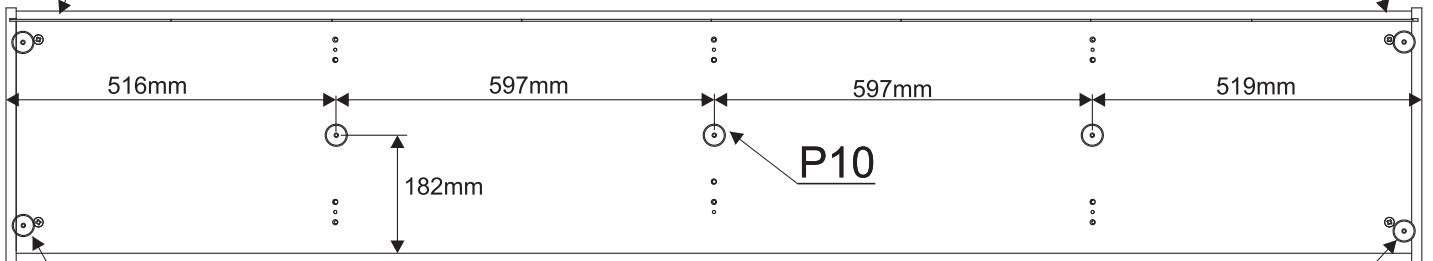
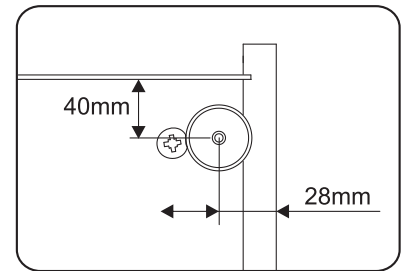
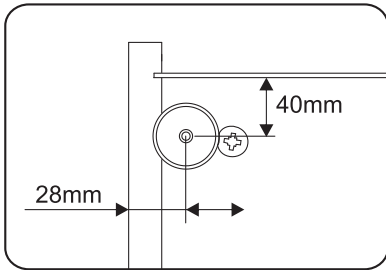
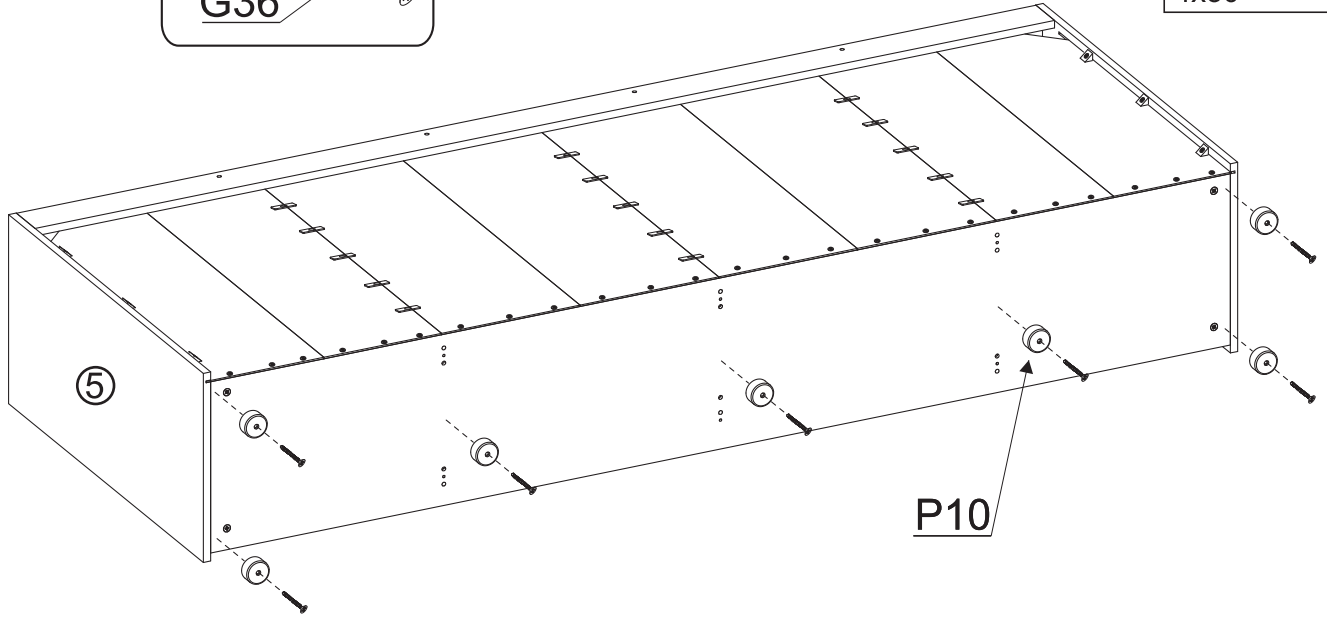



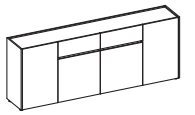

# XVI

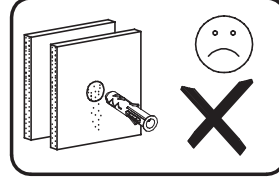
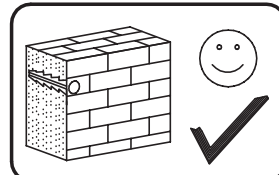
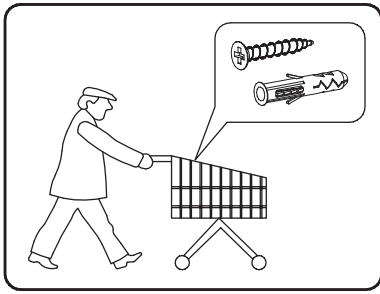

G34



3,5x16

x2

M11

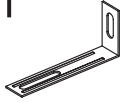

x2

I7



x10

G49



4x16



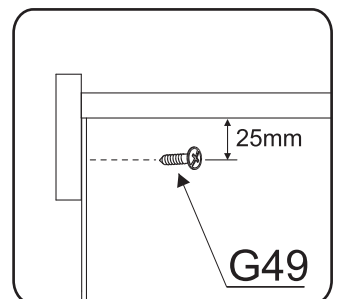
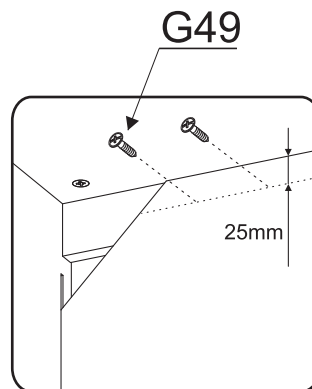
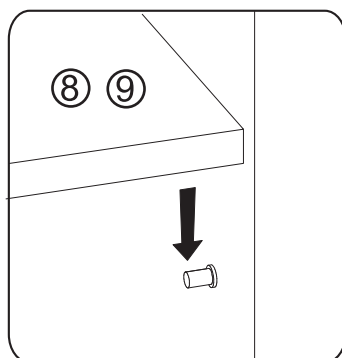
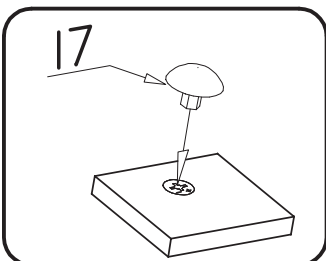
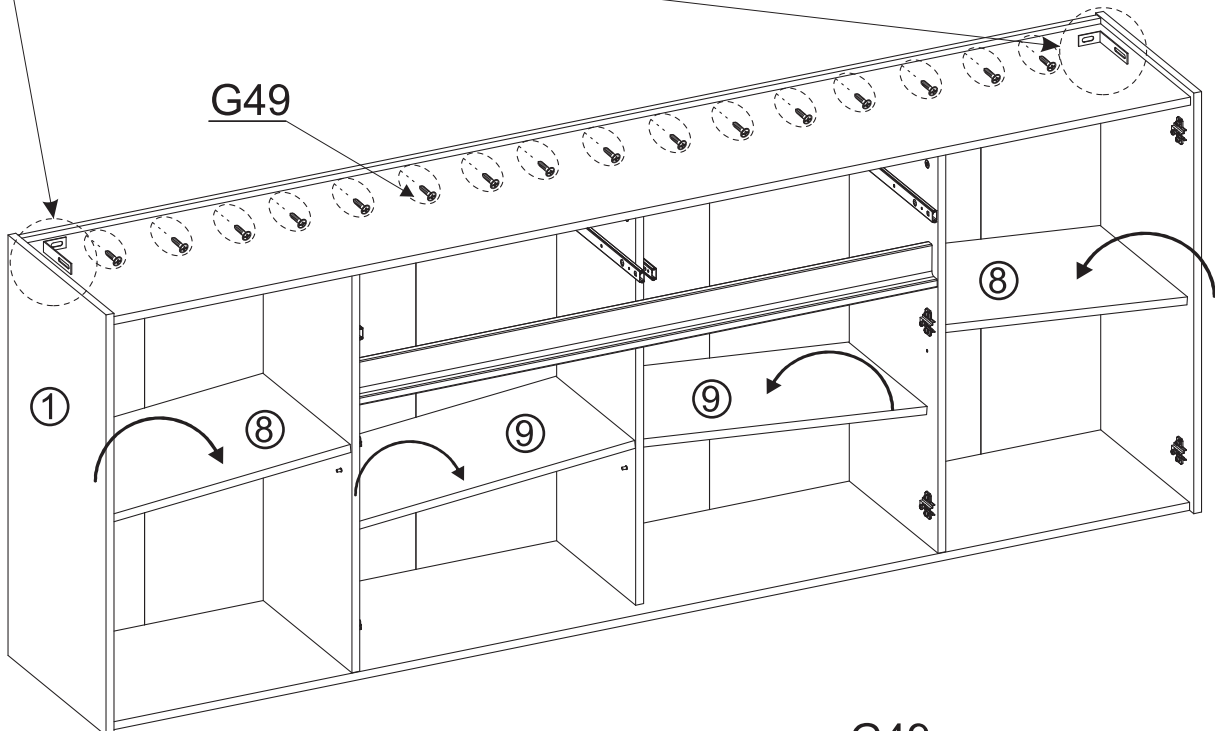
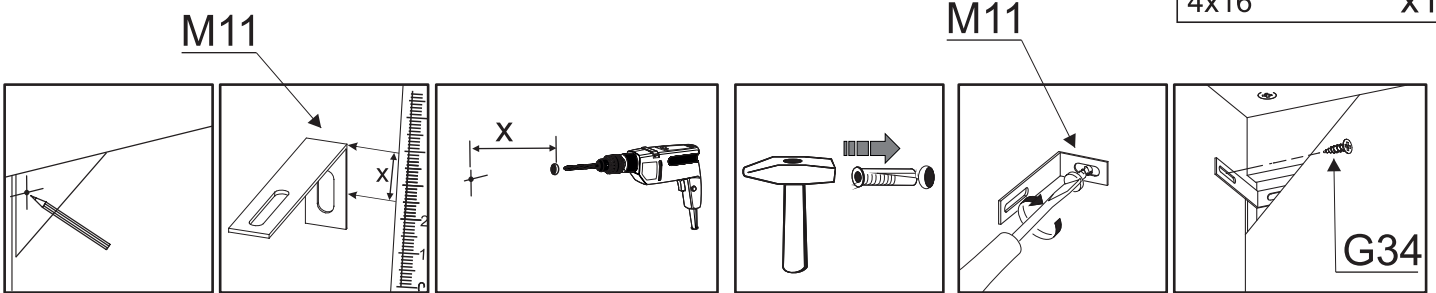

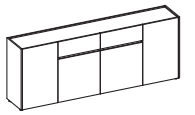
x16



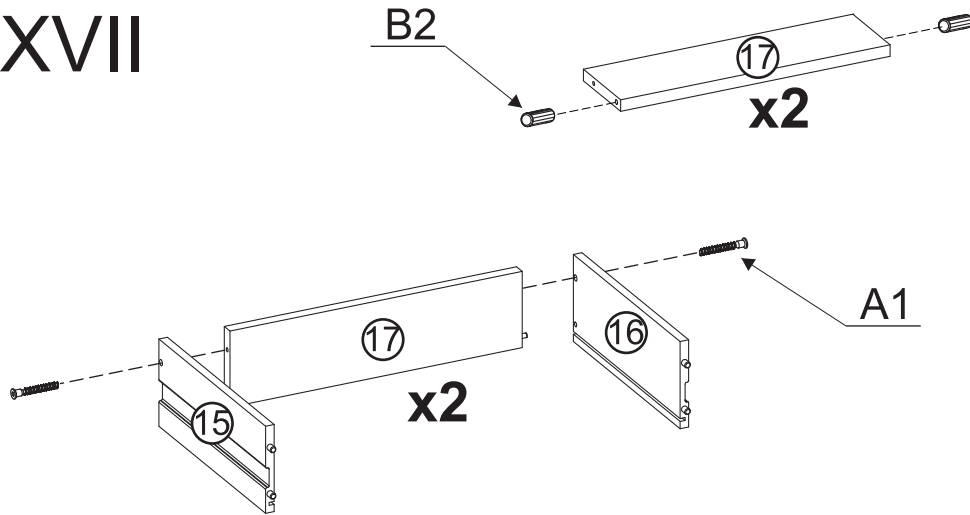

XVII

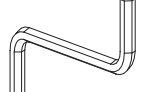

- B2  x4  
ø6x30
- A1  x4  
ø7x50
- W2  x1
- W1  x1

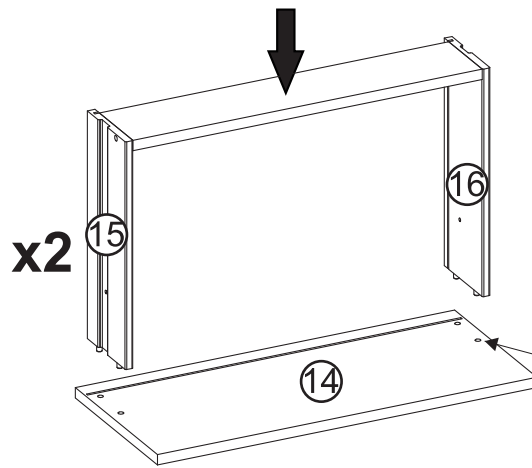

0,5h

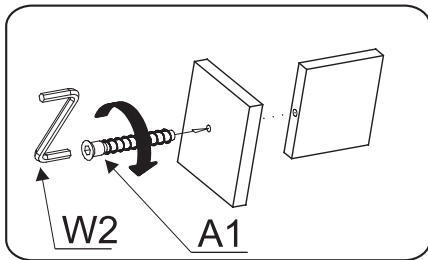
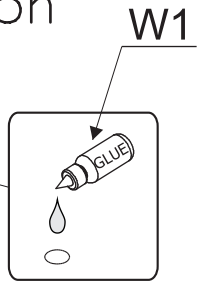

XVIII

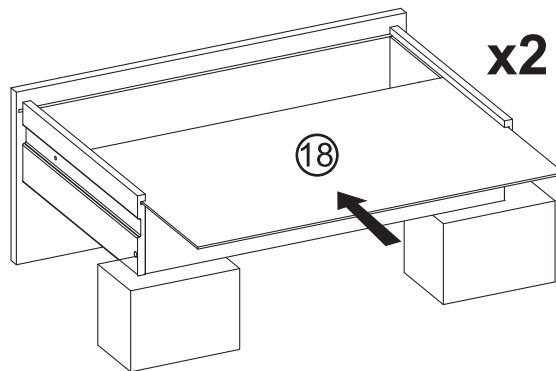

- G50  x12  
3x20

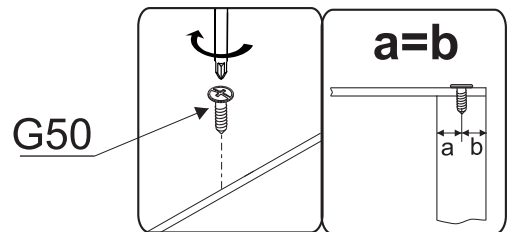
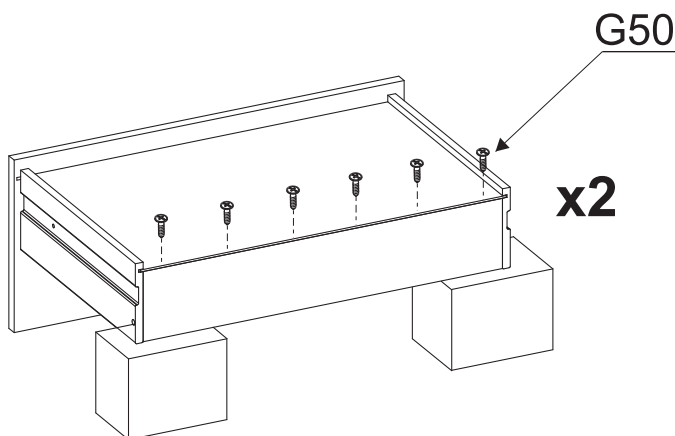

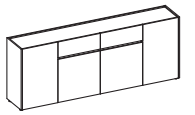

# XIX

N1

M4X9



x4

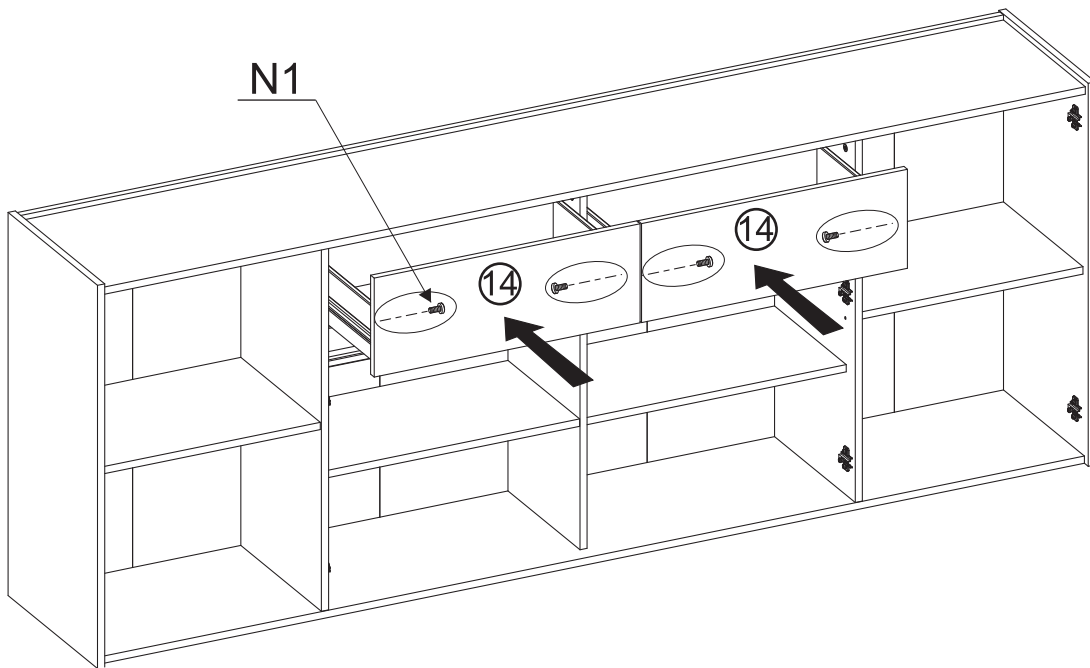
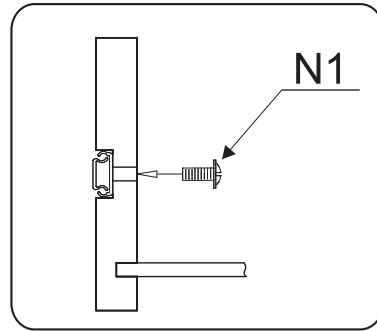
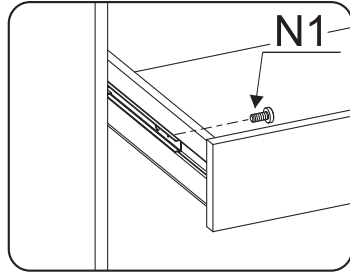
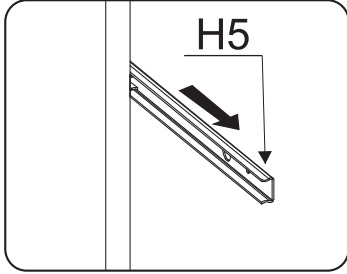

# XX

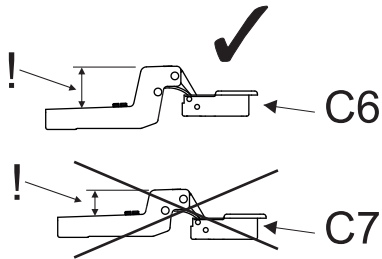

C6

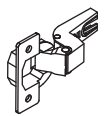

x4

G34



3,5x16

x8

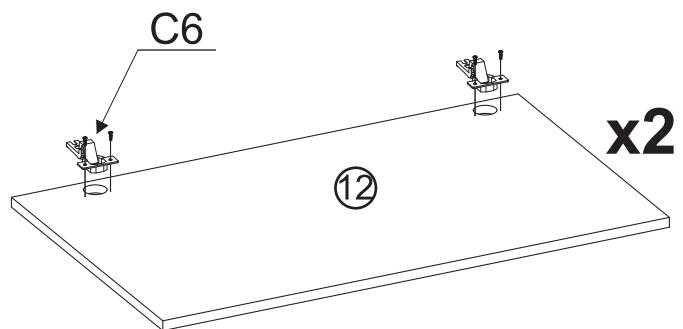
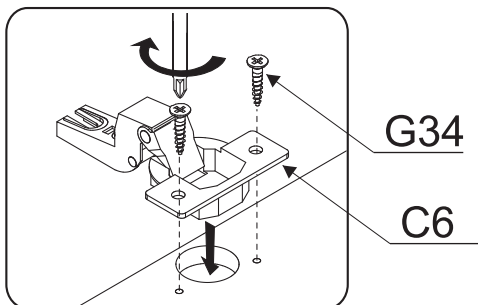

x2

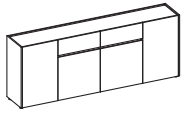

# XXI

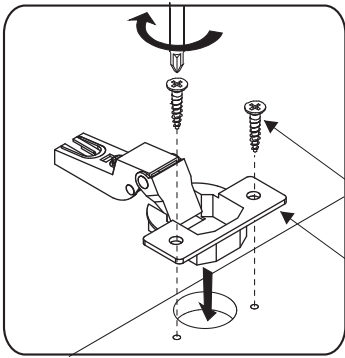

G34

C7

C7

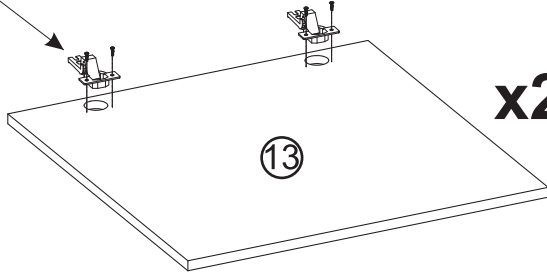

x2

C7

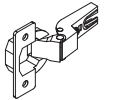

x4

G34



3,5x16

x8

# XXII

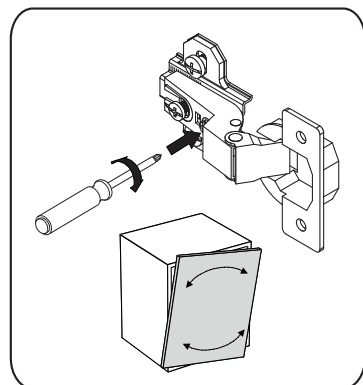
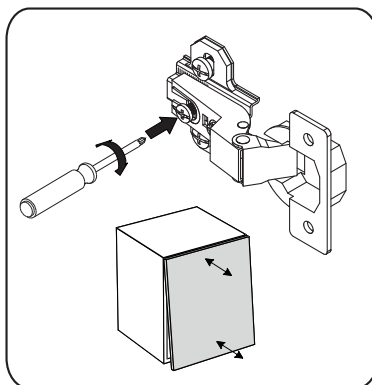
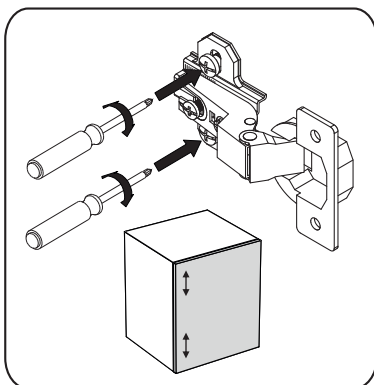
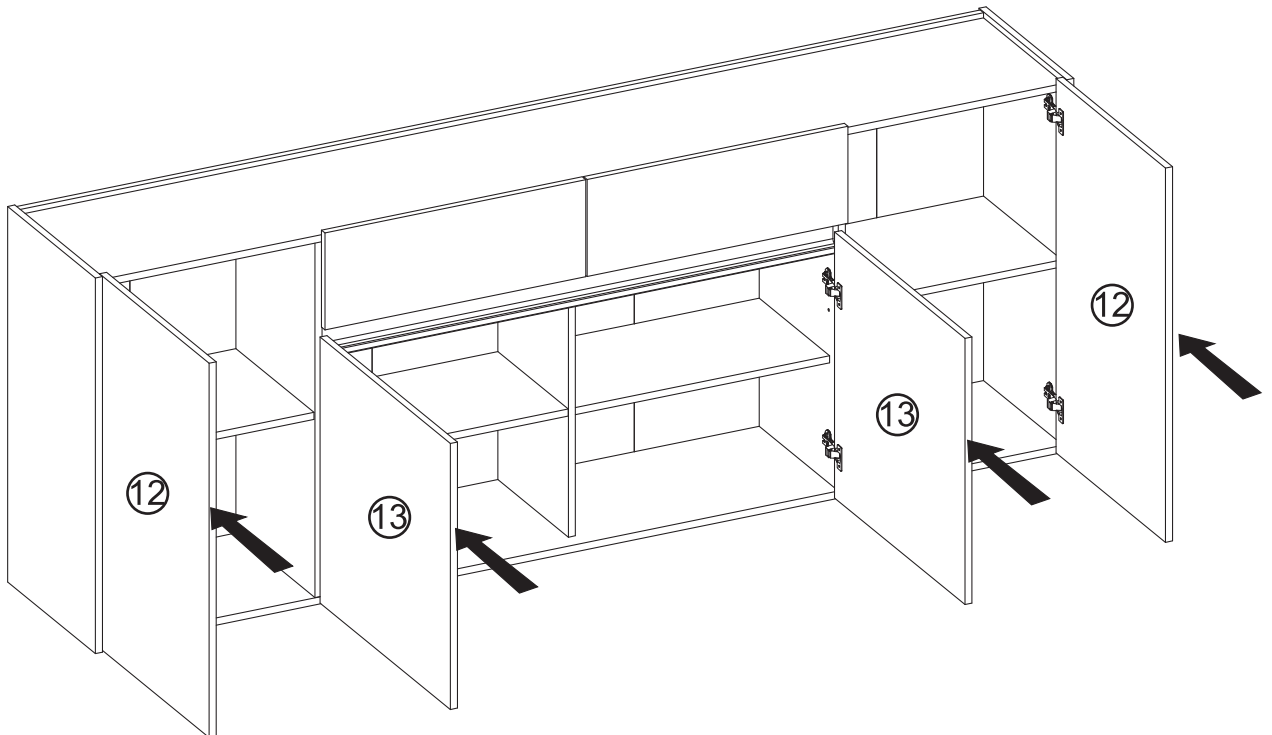
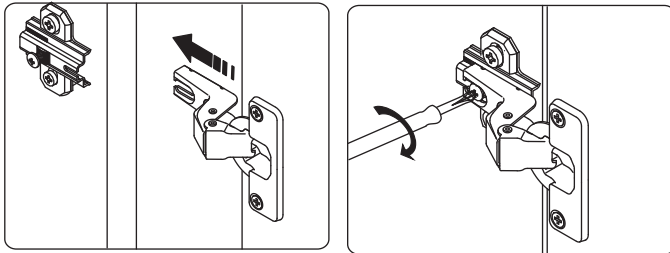

Name • Nom • Nome • Naam • Nazwa • Imięno • Názov • Név • Denumire • Isim • Имяне  
 Nr • No • N° • Номер • Č • Sz  
 Typ • Type • Tip • Típus • Tipo • Tun  
**CITY / GIRON** — — **52**

**Under Direktservice für Beschlagteile**

Sollte Ihnen ein Beschlagteil fehlen, können Sie diese Servicekarte direkt an die untenstehende Adresse mailen. Wir können allerdings nur Beschlagteile auf diesem Wege verschicken. Sollten Sie eine andere Beanstandung an Ihrem Möbelstück haben, so wenden Sie sich bitte direkt an Ihr Möbelhaus.

**Our direct order service for fitting**

If a fitting part is missing, you can e-mail this service card directly to the address below. However, we can only send fitting parts in this way. If you have any other cause for complaint concerning your item of furniture, please contact your furniture store directly.

**Naše přímé služby pro kování**

Chybí-li vám nějaký díl z kování, můžete tuto servisní kartu odeslat e-mailem přímo na níže uvedenou adresu. Touto cestou však můžeme rozesílat jen díly kování. Pokud byste reklamovali jiný díl nábytku, obraťte se přímo na svého prodejce nábytku.

**Bien etudier la notice de montage**

S'il vous manque une ferrure, veuillez envoyer directement la présente carte service à l'adresse e-mail indiquée ci-dessous. Cependant, ceci nous permet uniquement d'envoyer des ferrures. Pour tout autre type de réclamation concernant votre meuble, veuillez contacter directement votre magasin d'ameublement.

**Il nostro servizio diretto per l'ordine della ferramenta**

Qualora Vi dovesse mancare un pezzo di fissaggio, allora Vi preghiamo di inviare questa carta di servizio immediatamente all'indirizzo sottostante. Possiamo inviare i pezzi di fissaggio solamente per mezzo di questo procedimento. Qualora dovete avere qualche altra reclamazione in merito al mobile, allora Vi preghiamo di rivolgerVi direttamente al Vostro Negozio di mobili.

**Нашата директна услуга за обков**

Ако липсват части от комплекта, попълнете настоящата сервисна карта и ни я изпратете на e-mail адреса, посочен по-долу. По този начин можем да доставяме само липсващи елементи от обкова. Ако установите други дефекти по мебелите, Ви съветваме да се обърнете към мебелната къща/магазин, от който сте закупили стоката.

**Onze directservice voor losse onderdelen**

Wanneer er een onderdeel ontbreekt, kunt u deze servicekaart direct aan onderstaand e-mailadres sturen. Wij kunnen langs deze weg echter alleen beslagdelen versturen. Mocht u een ander probleem aan uw meubel hebben, verzoeken wij u contact op te nemen met uw meubeldealer.

**Nasz bezpośredni serwis części montażowych**

Jeżeli brakuje części koniecznych do montażu, prosimy o przesłanie nam niniejszej karty serwisowej na niżej podany adres e-mailowy. W ten sposób możemy przesłać Państwu tylko brakujące części. W przypadku innych reklamacji dotyczących mebla, prosimy zgłosić się do salonu meblowego, w którym został dokonany zakup.

**Servis za okove**

U slučaju da nedostaje neki od dijelova molimo vas da na dolje navedenu mail adresu pošaljete ovaj servisni obrazac. Na ovaj način mogu se dostaviti samo okovi. U slučaju da imate dodatne prigovore vezane uz komad namještaja molimo vas da se obratite izravno trgovini namještaja gdje je isti kupljen.

**Direktszolgáltatunk vasalatok esetén**

Ha hiányzik egy vasalat, ezt a kártyát közvetlenül elküldheti az alább található címre. Azonban csakis vasalatoskat tudunk így küldeni. Amennyiben másfajta reklamáció áll fenn bütördarabját illetően, forduljon közvetlenül a bútornáához.

**Náš priamy servis pre časti kovania**

Ak by Vám chýbala nejaká časť kovania, môžete poslať túto servisnú kartu poslať e-mailom na nižšie uvedenú adresu. Diely kovania vieme poslať iba týmto spôsobom. Ak by ste mali inú reklamáciu ohľadom Vášho nábytku, obráťte sa priamo na Vašu predajňu nábytku.

**Naše direktné služne stornice za okovje**

Če vam manjka kakšno okovje, lahko to servisno kartico pošljete po e-pošti direktno na spodnji naslov. Po tej poti vam lahko pošljemo samo okovje. Če želite reklamirati kakšen drug del pohištva, se obrnite neposredno na vašo trgovino pohištva.

**Service-ul nostru direct pentru feronerie**

În cazul în care vă lipsește o piesă de feronerie puteți să trimiteți direct acest card de service prin e-mail la adresa de mai jos. Noi nu putem expedia piese de feronerie decât pe această cale. Dacă aveți o altă reclamație referitoare la piesa de mobilier, atunci vă rugăm să vă adresați direct la magazinul dvs. de mobilă.

**Наш прямой сервис для поставок фурнитуры**

Если окажется, что Вам не хватает того или иного элемента фурнитуры, Вы можете отправить сервисную карту по факсу непосредственно на нижеприведенный адрес электронной почты. Однако, таким образом мы можем пересылать лишь фурнитуру. Если же у Вас возникнут иные претензии относительно приобретенной мебели, пожалуйста, обращайтесь непосредственно в организацию, осуществившую продажу.

**Vår direktservice för beslagsdelar**

Om du saknar en beslagsdel kan du skicka detta servicekort direkt till e-postadressen som anges nedan. Tänk på att detta är den enda möjligheten att skicka beslagsdelar till dig. Om du vill reklamera din möbel av en annan anledning måste du kontakta ditt möbelhus direkt.









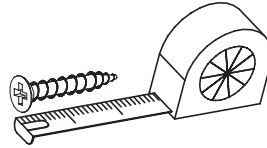



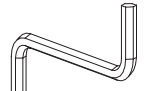
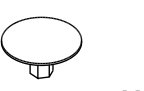





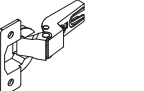
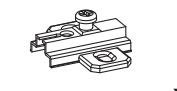

**Nuestro servicio directo para accesorios**

Si le falta algún accesorio, puede enviar esta tarjeta de servicio directamente a la siguiente dirección. No obstante, por este método solo podemos enviar accesorios. Si tiene alguna otra objeción sobre su mueble, consulte directamente con su mueblería.

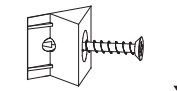
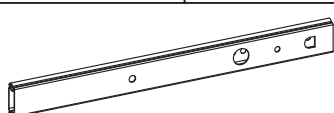
**Donatilar için doğrudan servisimiz**

Bir donatınız eksikse bu servis kartını doğrudan aşağıda bulunan adrese doğrudan mail yazabilirsiniz. Sadece bu yölla donatıları gönderebiliriz. Mobilyanızda başka şikayetleriniz varsa lütfen doğrudan mobilya satıcınıza danışın.

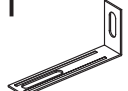
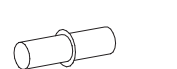

<b>B1</b>  ø8x35 X...	<b>B2</b>  ø6x30 X...	<b>A1</b>  ø7x50 X...
<b>W2</b>  X...	<b>I7</b>  X...	<b>K1</b>  X...
<b>K10</b>  X...	<b>D4</b>  X...	<b>C6</b>  X...
<b>G48</b>  6,3x13 X...	<b>C7</b>  X...	<b>D5</b>  X...
<b>G34</b>  3,5x16 X...	<b>G47</b>  6,3x13 X...	<b>G49</b>  4x16 X...
<b>F13</b>  X...	<b>N1</b>  M4x9 X...	<b>I1</b>  X...
<b>H5</b>  X...	<b>G50</b>  3x20 X...	
<b>P10</b>  X...	<b>G36</b>  4x30 X...	<b>Z6</b>  X...
<b>W1</b>  X...	<b>M11</b>  X...	<b>F2</b>  X...

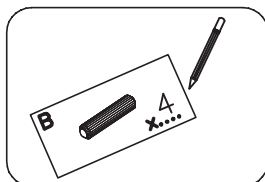

Name • Nom • Nome • Naam • Nazwa • Iméno  
• Názov • Név • Denumire • Isim • Имя

Nr • No • N° • Номер • Č • Sz

Typ • Type • Tip • Típus • Tipo • Tun

CITY / GIRON

— —

52

**D** Unser Direktservice für Beschlagteile

Sollte Ihnen ein Beschlagteil fehlen, können Sie diese Servicekarte direkt an die untenstehende Adresse mailen. Wir können allerdings nur Beschlagteile auf diesem Wege verschicken. Sollten Sie eine andere Beanstandung an Ihrem Möbelstück haben, so wenden Sie sich bitte direkt an Ihr Möbelhaus.

**GB** Our direct order service for fitting

If a fitting part is missing, you can e-mail this service card directly to the address below. However, we can only send fitting parts in this way. If you have any other cause for complaint concerning your item of furniture, please contact your furniture store directly.

**CZ** Naše přímé služby pro kování

Chybí-li vám nějaký díl z kování, můžete tuto servisní kartu odeslat e-mailem přímo na níže uvedenou adresu. Touto cestou však můžeme rozesílat jen díly kování. Pokud byste reklamovali jiný díl nábytku, obraťte se přímo na svého prodejce nábytku.

**F** Bien etudier la notice de montage

S'il vous manque une ferrure, veuillez envoyer directement la présente carte service à l'adresse e-mail indiquée ci-dessous. Cependant, ceci nous permet uniquement d'envoyer des ferrures. Pour tout autre type de réclamation concernant votre meuble, veuillez contacter directement votre magasin d'ameublement.

**I** Il nostro servizio diretto per l'ordine della ferramenta

Qualora Vi dovesse mancare un pezzo di fissaggio, allora Vi preghiamo di inviare questa carta di servizio immediatamente all'indirizzo sottostante. Possiamo inviare i pezzi di fissaggio solamente per mezzo di questo procedimento. Qualora dovete avere qualche altra reclamazione in merito al mobile, allora Vi preghiamo di rivolgerVi direttamente al Vostro Negozio di mobili.

**BG** Нашата директна услуга за обков

Ако липсват части от комплекта, попълнете настоящата сервисна карта и ни я изпратете на e-mail адреса, посочен по-долу. По този начин можем да доставяме само липсващи елементи от обкова. Ако установите други дефекти по мебелите, Ви съветваме да се обърнете към мебелната къща/магазин, от който сте закупили стоката.

**NL** Onze directservice voor losse onderdelen

Wanneer er een onderdeel ontbreekt, kunt u deze servicekaart direct aan onderstaand e-mailadres sturen. Wij kunnen langs deze weg echter alleen beslagdelen versturen. Mocht u een ander probleem aan uw meubel hebben, verzoeken wij u contact op te nemen met uw meubeldealer.

**PL** Nasz bezpośredni serwis części montażowych

Jeżeli brakuje części koniecznych do montażu, prosimy o przesłanie nam niniejszej karty serwisowej na niżej podany adres e-mailowy. W ten sposób możemy przesyłać Państwu tylko brakujące części. W przypadku innych reklamacji dotyczących mebla, prosimy zgłosić się do salonu meblowego, w którym został dokonany zakup.

**HR** Servis za okove

U slučaju da nedostaje neki od dijelova molimo vas da na dolje navedenu mail adresu pošaljete ovaj servisni obrazac. Na ovaj način mogu se dostaviti samo okovi. U slučaju da imate dodatne prigovore vezane uz komad namještaja molimo vas da se obratite izravno trgovini namještaja gdje je isti kupljen.

**HU** Direktszolgáltatunk vasalatok esetén

Ha hiányzik egy vasalat, ezt a kártyát közvetlenül elküldheti az alább található címre. Azonban csakis vasalatókat tudunk így küldeni. Amennyiben másfajta reklamáció áll fenn bütördarabját illetően, forduljon közvetlenül a bútornáhzoz.

**SK** Naš priamy servis pre časti kovania

Ak by Vám chýbala nejaká časť kovania, môžete poslať túto servisnú kartu poslať e-mailom na nižšie uvedenú adresu. Diely kovania vieme poslať iba týmto spôsobom. Ak by ste mali inú reklamáciu ohľadom Vášho nábytku, obráťte sa priamo na Vašu predajňu nábytku.

**SLO** Naše direktne služne storitve za okovje

Če vam manjka kakšno okovje, lahko to servisno kartico pošljete po e-pošti direktno na spodnji naslov. Po tej poti vam lahko pošljemo samo okovje. Če želite reklamirati kakšen drug del pohištva, se obrnite neposredno na vašo trgovino pohištva.

**RO** Service-ul nostru direct pentru feronerie

În cazul în care vă lipsește o piesă de feronerie puteți să trimiteți direct acest card de service prin e-mail la adresa de mai jos. Noi nu putem expedia piese de feronerie decât pe această cale. Dacă aveți o altă reclamație referitoare la piesa de mobilier, atunci vă rugăm să vă adresați direct la magazinul dvs. de mobilă.

**RUS** Наш прямой сервис для поставок фурнитуры

Если окажется, что Вам не хватает того или иного элемента фурнитуры, Вы можете отправить сервисную карту по факсу непосредственно на нижеприведенный адрес электронной почты. Однако, таким образом мы можем пересылать лишь фурнитуру. Если же у Вас возникнут иные претензии относительно приобретенной мебели, пожалуйста, обращайтесь непосредственно в организацию, осуществившую продажу.

**S** Vår direktservice för beslagsdelar

Om du saknar en beslagsdel kan du skicka detta servicekort direkt till e-postadressen som anges nedan. Tänk på att detta är den enda möjligheten att skicka beslagsdelar till dig. Om du vill reklamera din möbel av en annan anledning måste du kontakta ditt möbelhus direkt.

**ES** Nuestro servicio directo para accesorios

Si le falta algún accesorio, puede enviar esta tarjeta de servicio directamente a la siguiente dirección. No obstante, por este método solo podemos enviar accesorios. Si tiene alguna otra objeción sobre su mueble, consulte directamente con su mueblería.

**TR** Donatılar için doğrudan servisimiz

Bir donatınız eksikse bu servis kartını doğrudan aşağıda bulunan adrese doğrudan mail yazabilirsiniz. Sadece bu yöllä donatıları gönderebiliriz. Mobilyanızda başka şikayetleriniz varsa lütfen doğrudan mobilya satıcınıza danışın.

nr	L[mm]	B[mm]	T[mm]	Menge	Colli
1	840	400	16	1	1/3
2	795	361	16	1	1/3
3	795	322	16	1	3/3
4	795	361	16	1	1/3
5	850	400	16	1	1/3
6	2200	366	16	1	3/3
7	2200	362	16	1	3/3
8	495	356	16	2	1/3
9	582	321	16	2	3/3
10	2200	80	16	1	3/3
11	1178	77	38	1	3/3

nr	L[mm]	B[mm]	T[mm]	Menge	Colli
12	837	500	16	2	1/3
13	565	595	16	2	1/3
14	595	217	16	2	2/3
15	350	120	12	2	2/3
16	350	120	12	2	2/3
17	548	105	12	2	2/3
18	559	358	3	1	1/3
19	808	508	3	1	1/3
20	808	598	3	2	1/3
21	808	508	3	1	1/3

